

# THE HISTORICAL COLLECTION OF PHYSICS INSTRUMENTS: EDUCATIONAL ASPECTS

---

Aurelio Agliolo Gallitto, [aurelio.agliologallitto@unipa.it](mailto:aurelio.agliologallitto@unipa.it)

*Dipartimento di Fisica e Chimica, Università degli Studi di Palermo*



UNIVERSITÀ  
DEGLI STUDI  
DI PALERMO

MUSEIUNIPA  
Sistema Museale dell'Università degli Studi di Palermo

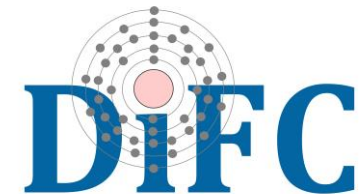

# THE MUSEUM SYSTEM OF THE UNIVERSITY OF PALERMO

---

In 2011, the University of Palermo instituted the University Museum System (SiMuA) to coordinate all the museum activities to foster the development of their activities and making them accessible to the public at large.

**The SiMuA coordinates 6 Museums and 13 Collections.**



- The Museum of Zoology "P. Doderlein"
- The Botanical Garden
- The Museum of Geology "G. G. Gemmellaro"
- The "Specola" and the Astronomical Observatory
- The Museum of Radiology
- The Museum of Engines and Mechanisms

# THE MUSEUM OF ZOOLOGY "P. DODERLEIN"

---



# THE BOTANICAL GARDEN

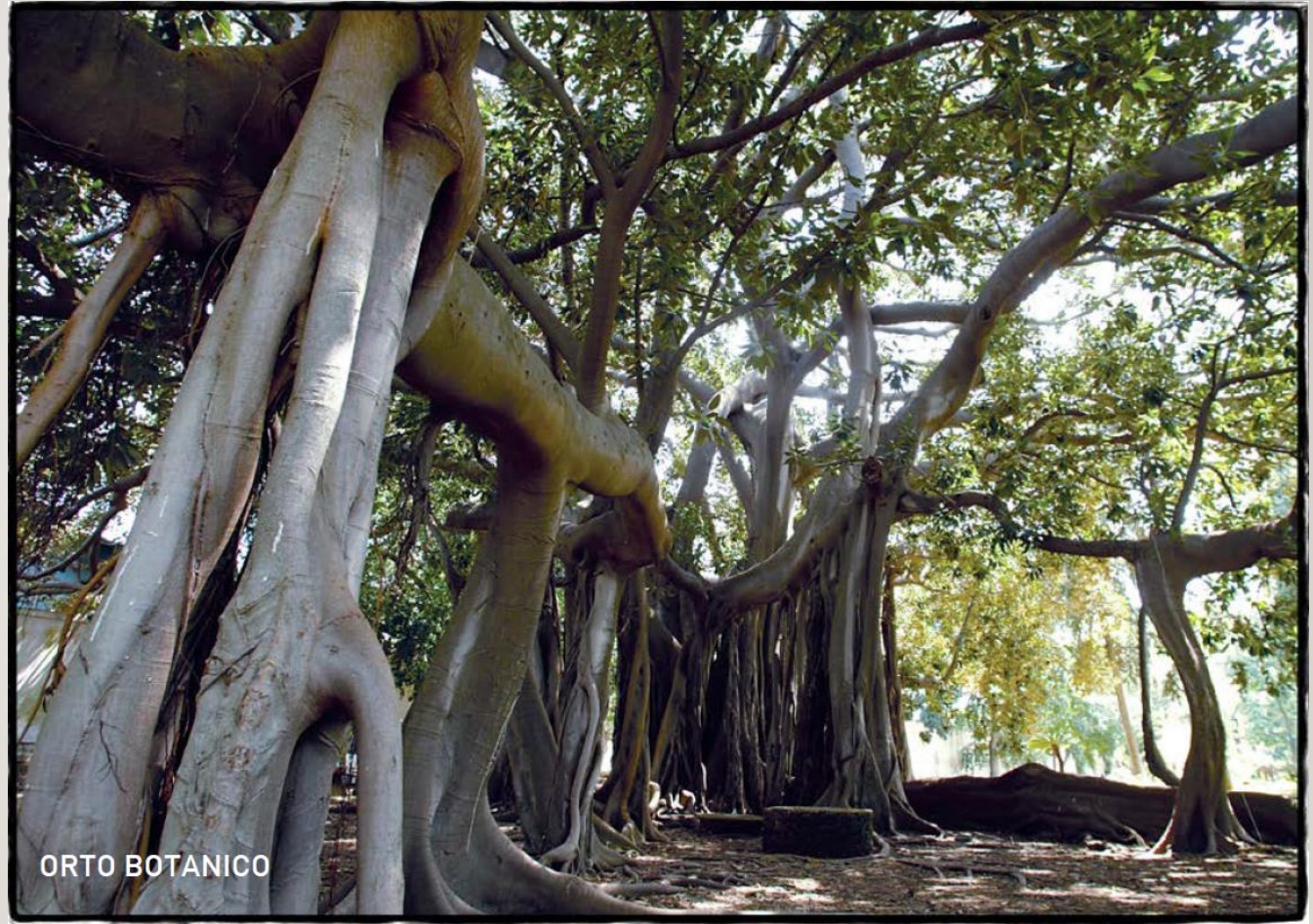

# THE MUSEUM OF GEOLOGY "G.G. GEMMELLARO"



Thea, a prehistoric human of Sicily.



The dwarf elephants lived in Sicily between 500 and 120 thousand years ago.



# THE MUSEUM OF SPECOLA AND THE ASTRONOMICAL OBSERVATORY

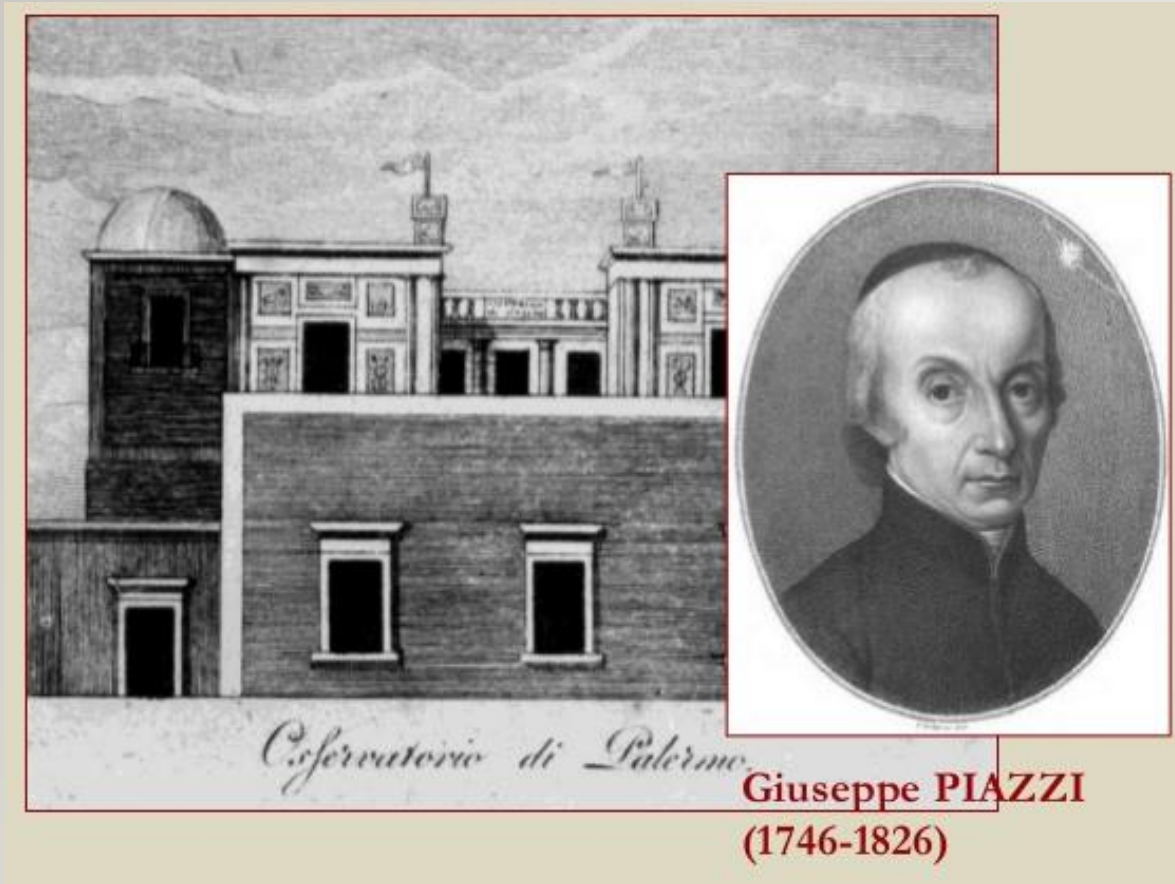

The Astronomical Observatory at the top of the Tower Pisana, founded in 1786 under the Bourbons.

Aurelio Agliolo Gallitto



The great astronomical circle of 1789 that Jesse Ramsden built for the observatory of Palermo.

Source: MEDIA INAF



# THE MUSEUM OF RADIOLOGY

---



The **Museum of Radiology** was inaugurated in **1995** during the celebrations of the centennial of the **discovery of the X-ray in 1895** by **Wilhelm Conrad Roentgen (1845 – 1923)**.

# THE MUSEUM OF ENGINES AND MECHANISMS





# SOME ACTIVITIES OF THE MUSEUM SYSTEM: VIRTUAL TOURS

A large effort has been devoted to the realization of *Virtual Tours*: online interactive 360° panoramic photos, to ensures an immersive feeling and high user's involvement.

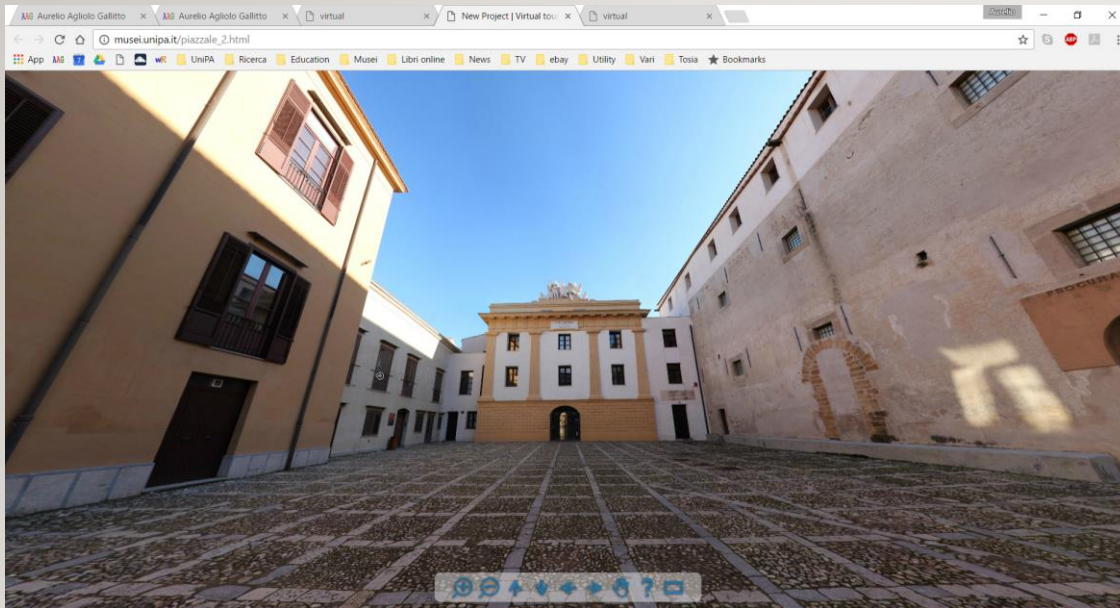

[musei.unipa.it/piazzale\\_2.html](http://musei.unipa.it/piazzale_2.html)

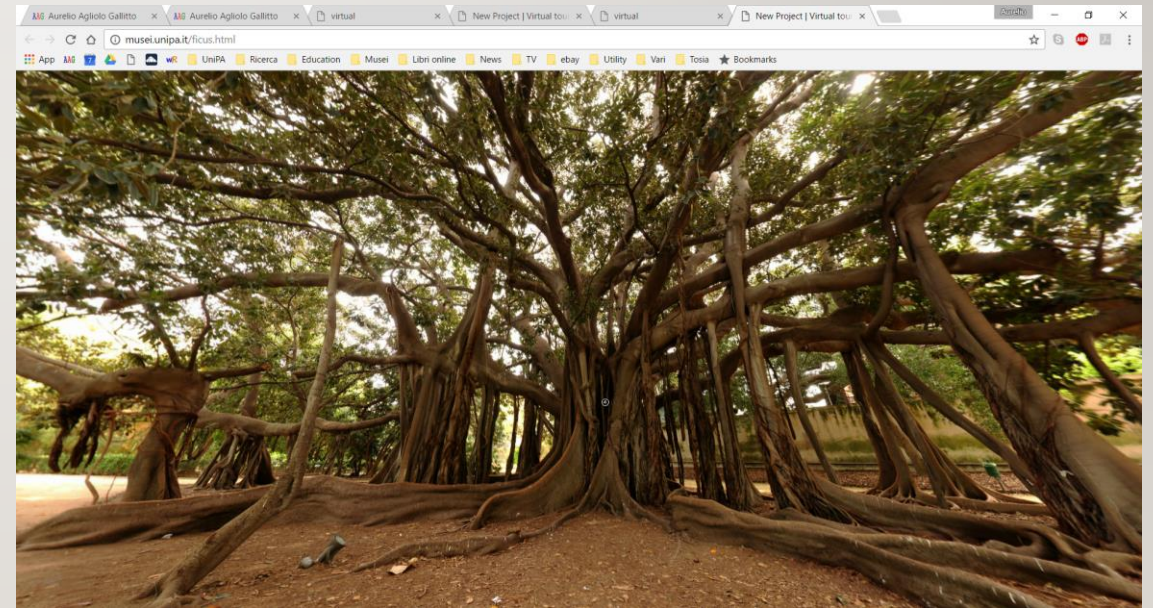

[musei.unipa.it/ficus.html](http://musei.unipa.it/ficus.html)

# THE ISTITUTO DI FISICA AND ITS HISTORICAL COLLECTION

---

The Historical Collection of Physics Instruments is displayed at the Department of Physics and Chemistry in the historical building of via Archirafi 36.

The oldest instruments date back to the early 19<sup>th</sup> century, when experimental Physics began to be taught in the University by using instruments and apparatus.

The Collection today consists of more than 500 items.



The historical building of the Istituto di Fisica of via Archirafi 36

# THE ISTITUTO DI FISICA AND ITS HISTORICAL COLLECTION (2)

## Padre Eliseo della Concezione (1725 - 1809)

Titolare della cattedra di Fisica Sperimentale dal 1786 fino al 1811. Si occupò di ricerca sperimentale nel campo della chimica pneumatica, la respirazione e la dottrina dei nuovi gas con quella del flogisto. Partecipò, come cartografo, alla spedizione in Calabria dopo il terremoto del 1783.

*He holds the Chair of Experimental Physics from 1786 to 1811. He was involved in experimental research in the field of pneumatic chemistry, respiration and the theory of new gases with the phlogiston theory. He participated as a cartographer in the expedition in Calabria after the earthquake of 1783.*

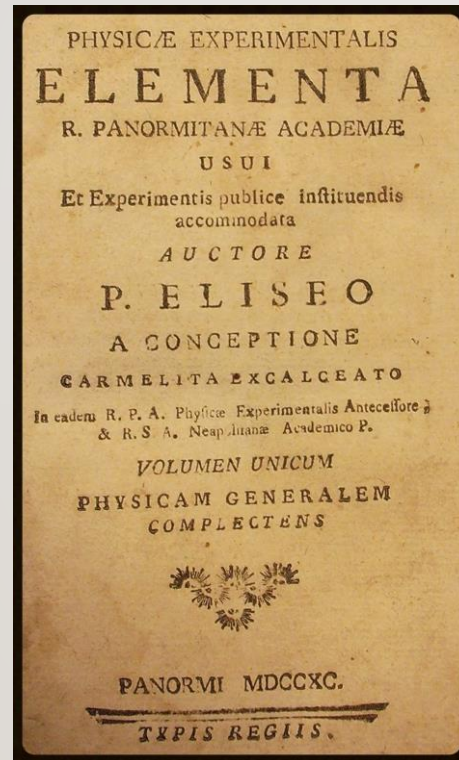

Showcases containig instruments

# MECHANICS

The equipment grows considerably after Domenico Scinà got the chair of Experimental Physics, in 1811, at the old “Gabinetto di Fisica” of the “Reale Università di Palermo”.

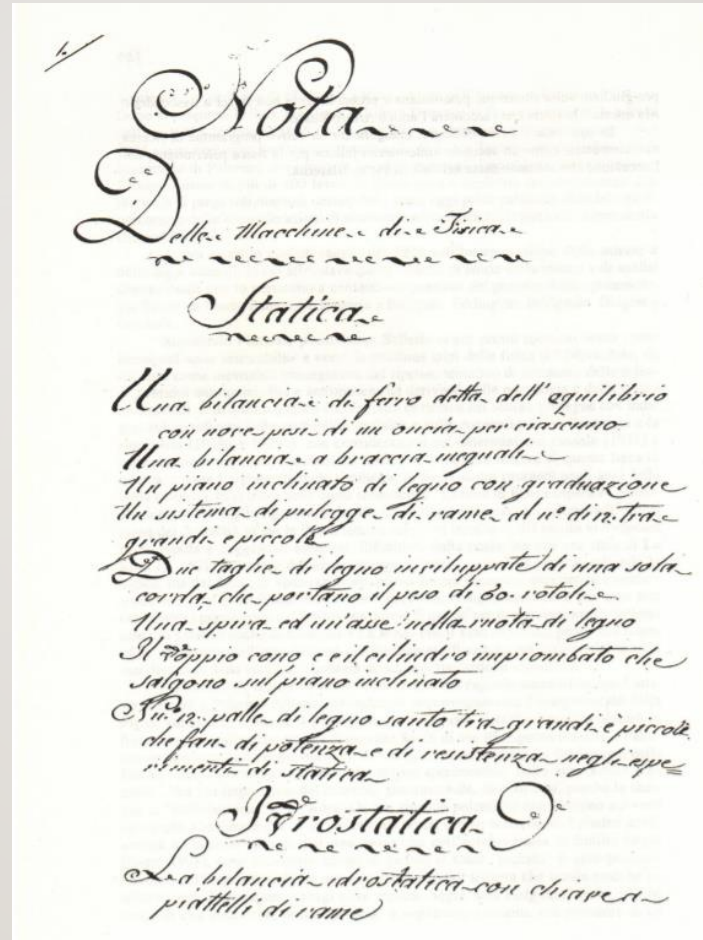
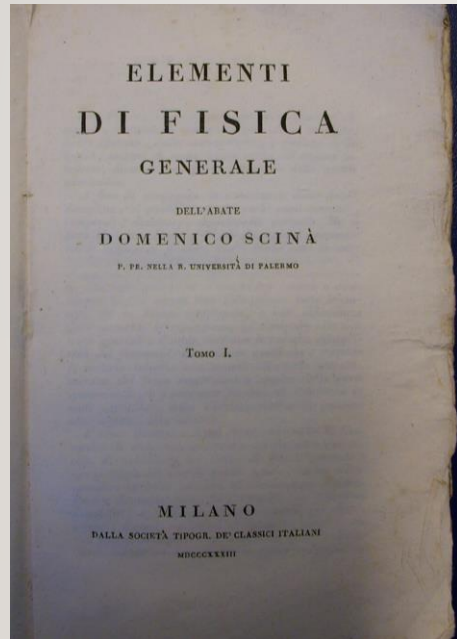

# MECHANICS (2)



Agliolo, Phys Educ **46** (2011) 682

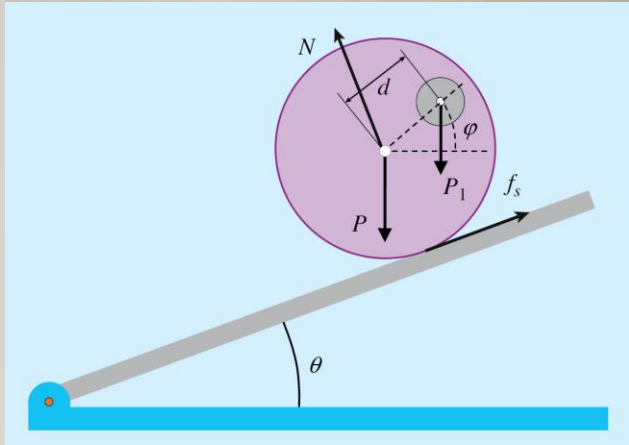

Aglione, Phys Educ **48** (2013) 137

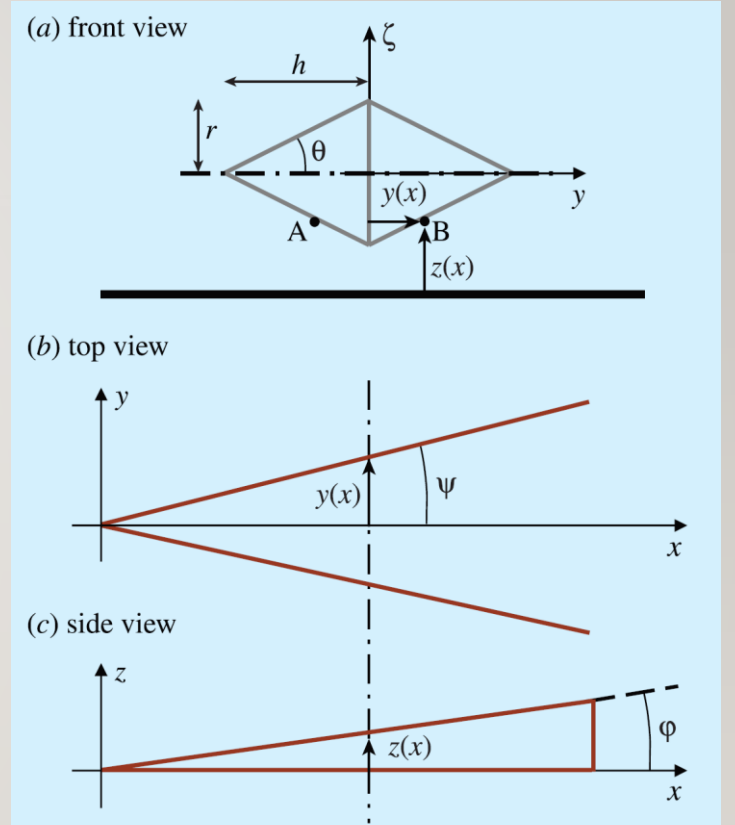

**Figure 2.** Schematic perspectives of the double cone and the rails: (a) front view of the double cone, (b) top view of the rails and (c) side view of the rails.

# OPTICS: DOMENICO RAGONA AND ROSARIO CARUSO

---



Newton's coloured rings (1841)



Refractometer (1843)

The Refractometer was built at Palermo in 1843 by the technician **Rosario Caruso** on the indication of **Domenico Ragona** (1820 - 1892) to demonstrate the laws of refraction and of the limit angle.

# PIETRO BLASERNA AND THE ACUSTICAL INSTRUMENTS



Pietro Blaserna (1836 - 1918)

In April 1863, Pietro Blaserna was appointed Professor of Experimental Physics at the University of Palermo. Here he published several works on electricity, optics, including one on the polarization of the solar corona observed in Augusta during the total eclipse of December 22, 1870 (*Il Nuovo Cimento* 6, 1871), and on heat (*Dynamic Heat Theory*, 1872).

*Nell'aprile del 1863, Pietro Blaserna fu nominato Professore di Fisica sperimentale all'Università di Palermo. Qui pubblicò vari lavori sull'elettricità, ottica, tra cui uno sulla polarizzazione della corona solare osservata in Augusta durante l'eclisse totale del 22 dicembre 1870 (Il Nuovo Cimento 6, 1871), e sul calore (Teoria dinamica del calore, 1872).*

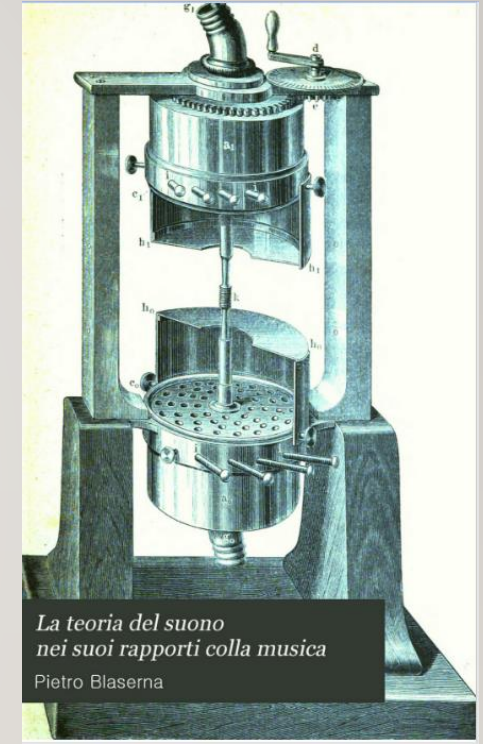

*La teoria del suono  
nei suoi rapporti colla musica*  
Pietro Blaserna

P. Blaserna, *The theory of sound in its relation to music*, H.S. King & Co. London 1876

# ACOUSTICS: ORGAN PIPES

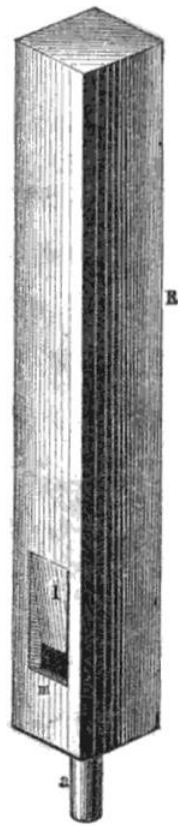
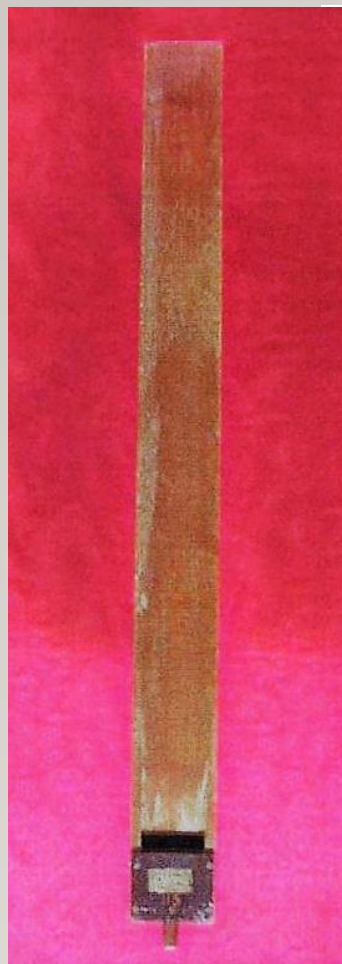

Fig. 8.

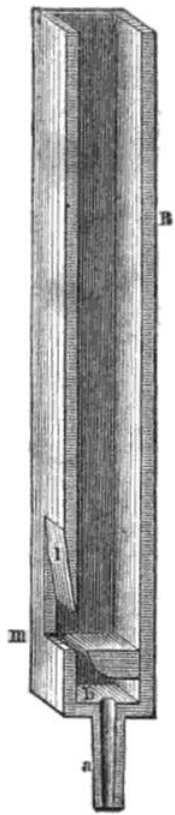

Fig. 9.

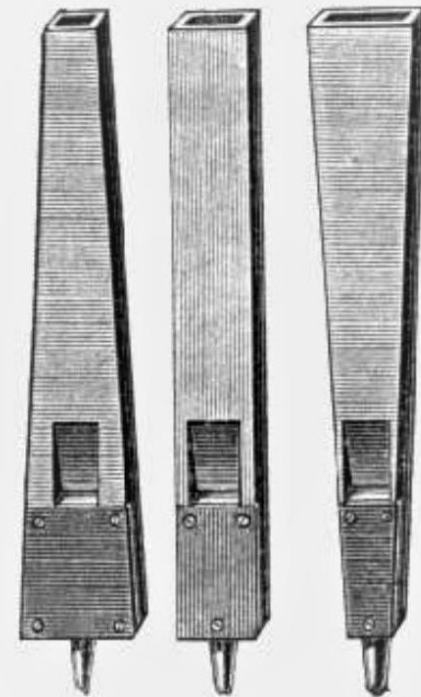
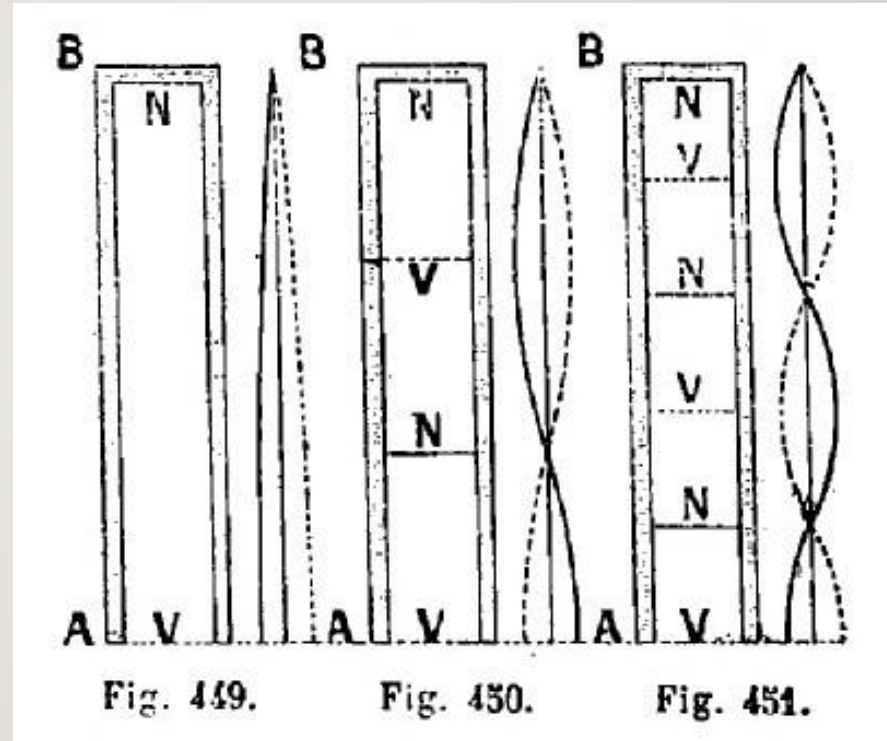
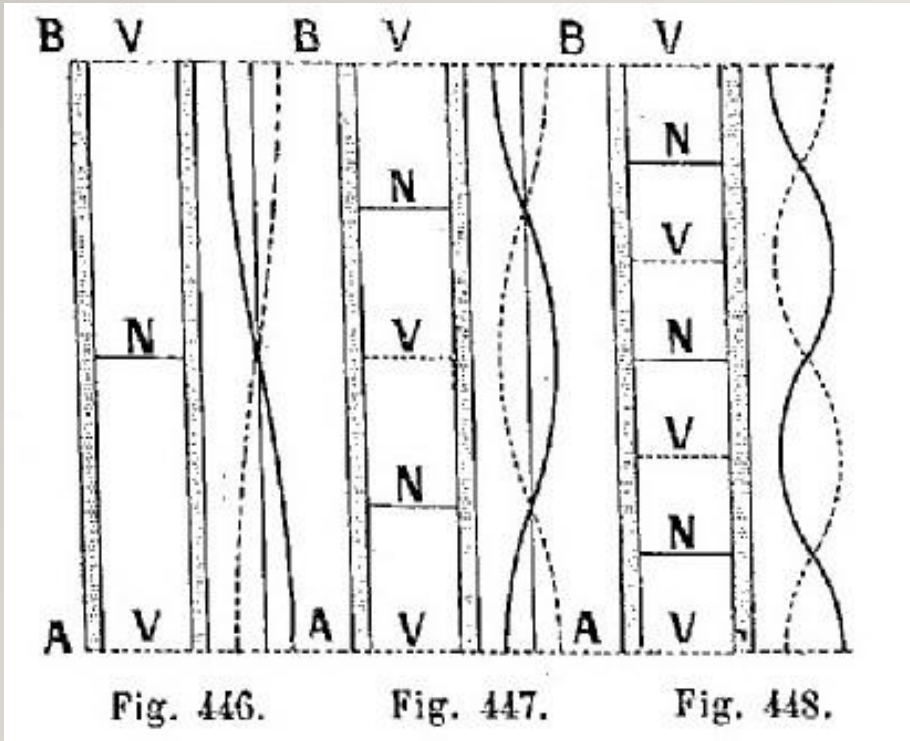

Fig. 56 (N° 111).



# ACOUSTICS: SOUND VIBRATIONS GENERATED BY PIPES



$$l = n \frac{\lambda}{2}$$

$$l = \left( n - \frac{1}{2} \right) \frac{\lambda}{2}$$



# ACOUSTICS: THE VISUALIZATION OF SOUND VIBRATIONS

---

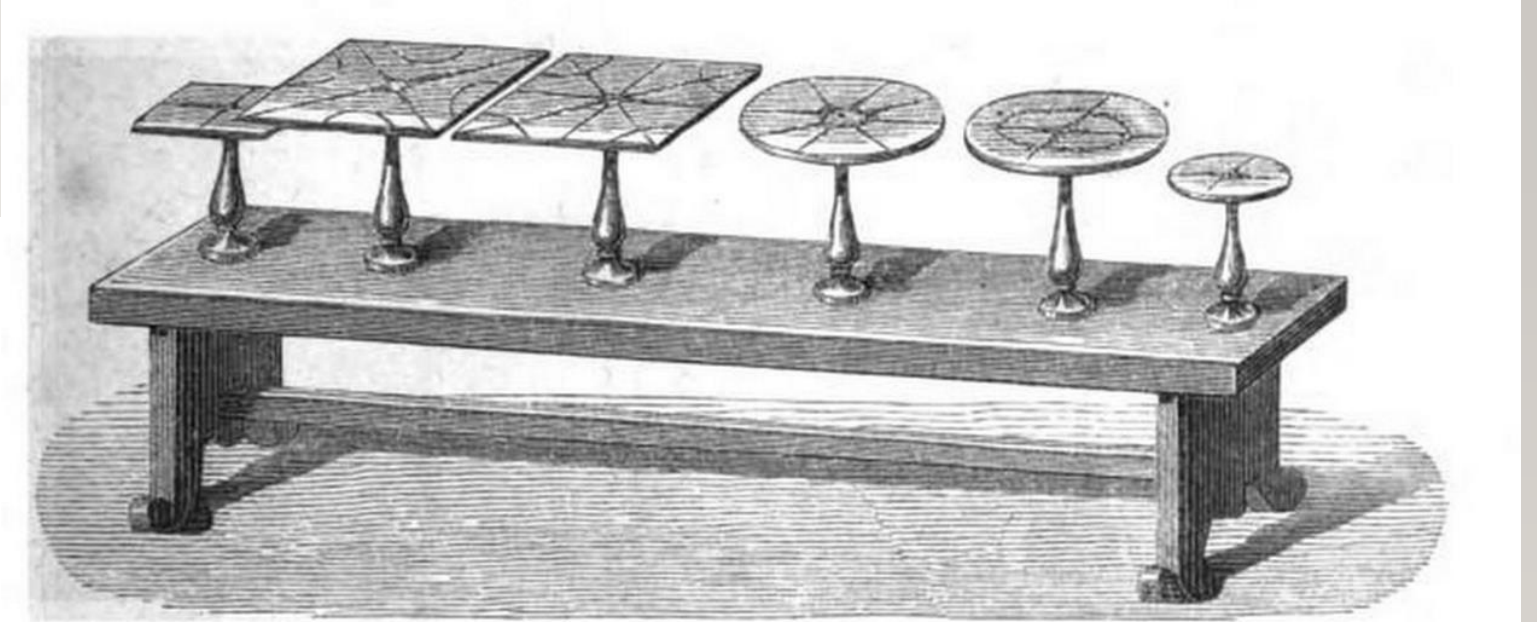
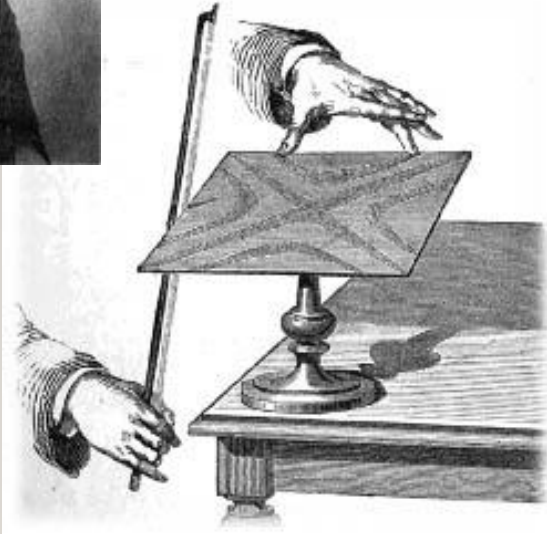
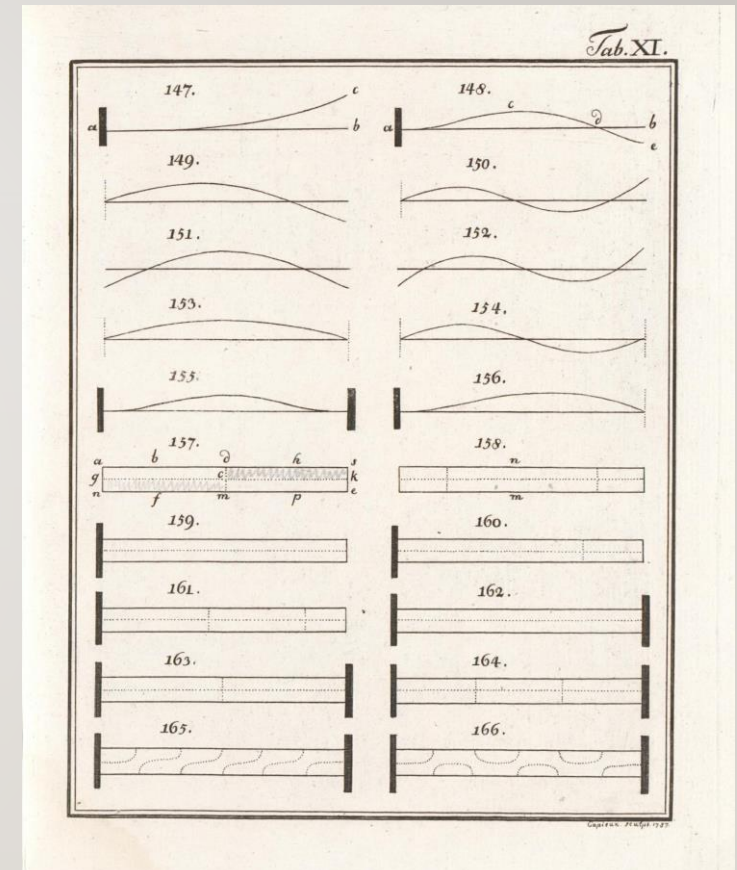
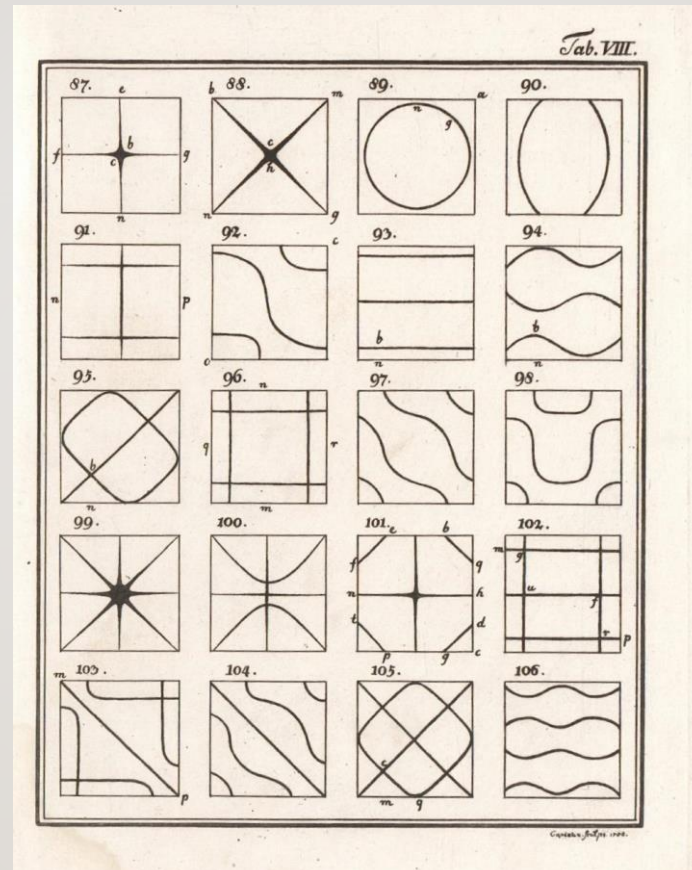
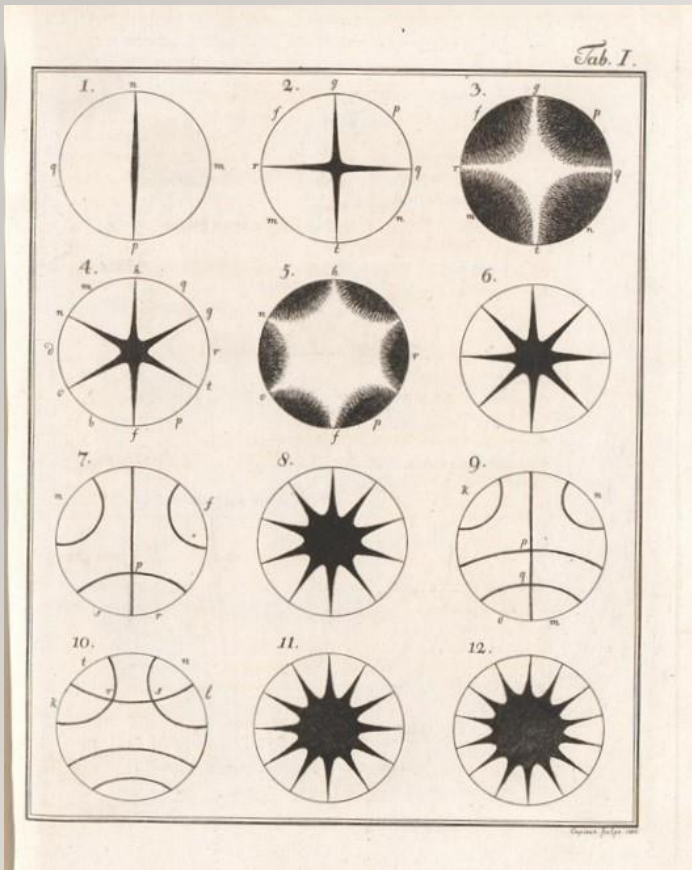

Fig. 6. Tavola di Chladni

Ernst Florens Friedrich Chladni (1756 - 1827)

# ACOUSTICS: CHLADNI'S FIGURES



E. F. F. Chladni, *Entdeckungen über die Theorie des Klanges*, Weidmanns Erben und Reich, Leipzig 1787

# ACOUSTICS: CHLADNI'S PLATES MADE BY RUDOLPH KOENIG IN 1864

---



*Rudolph Koenig*  
27, Quai d'Orléans.



«RUDOLPH KOENIG, the most distinguished living inventor and mechanic in the domain of acoustics»

W. Le Conte Stevens, *Sketch of Rudolph Koenig*, *Popular Science Monthly* 37 (1890) 545

# LA CAMPANA CINESE (O TIBETANA) AD ACQUA

Il **LONGXI**, bronzo cinese risalente a più di mille anni fa durante la dinastia Han, prende il nome dall'immagine di 4 draghi che compare sul fondo.

Il **LONGXI**, o campana cinese, forma dei zampilli d'acqua tramite attrito e risonanza, generando un fenomeno fisico simile a quello delle onde sonore. Sfregando i due manici della ciotola con le mani, dalla superficie dell'acqua si creano degli zampilli alti fino a 50 cm.



# ACOUSTICS: INTERFERENCE AND BEATS

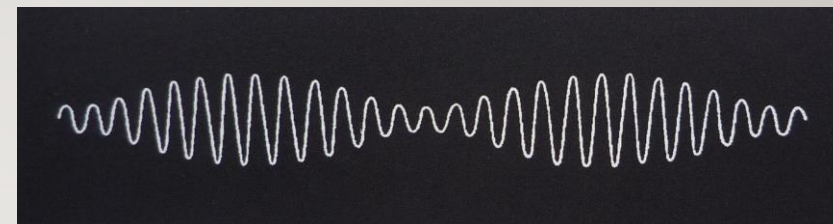
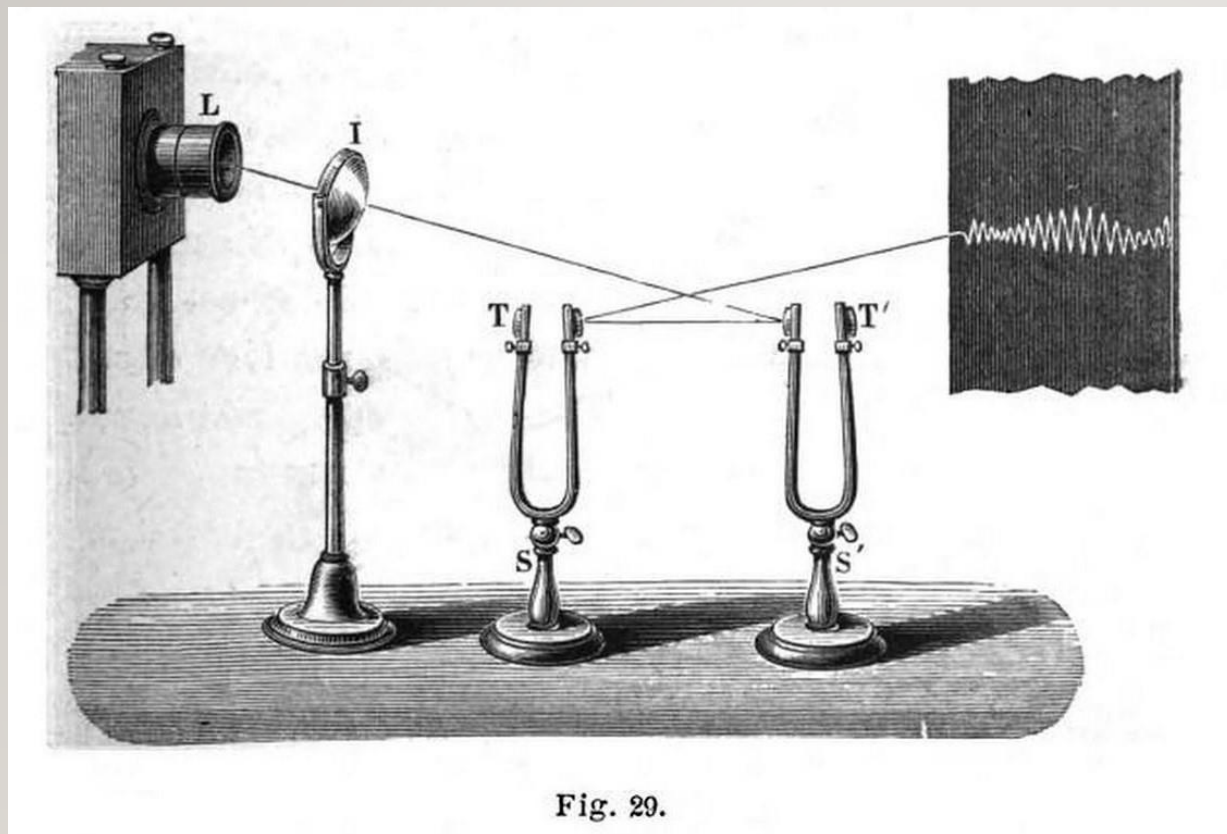

# LISSAJOUS FIGURES



In 1857, Jules Antoine Lissajous (1822 - 1880) thought of a method of reflecting a light beam from the arms of two vibrating tuning fork perpendicularly to each other.

*Nel 1857, Jules Antoine Lissajous (1822 - 1880) ha pensato un metodo per fare riflettere un fascio luminoso dai rebbi di due diapason vibranti perpendicolarmente l'uno dall'altro.*

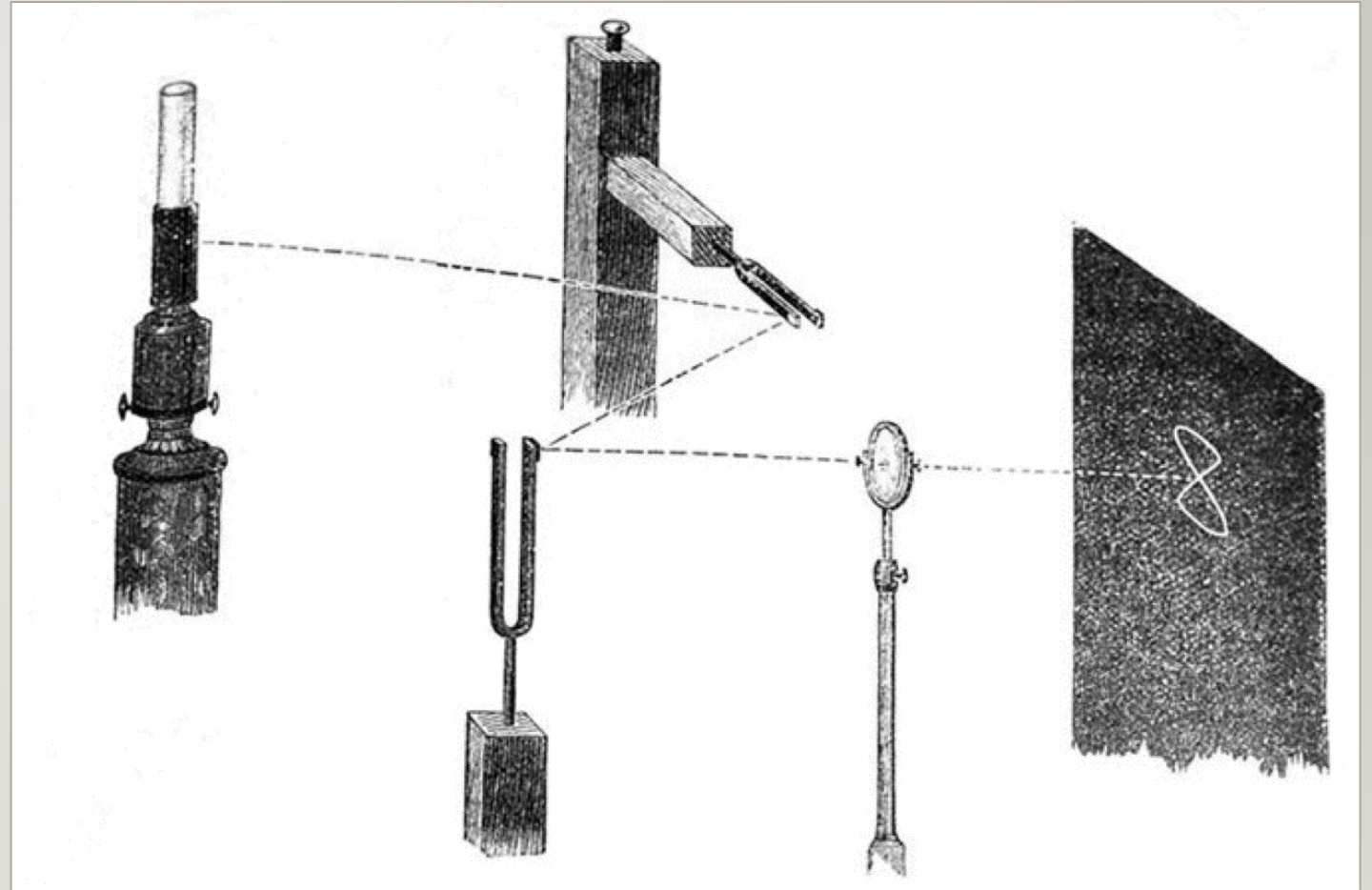

# LISSAJOUS FIGURES (2)

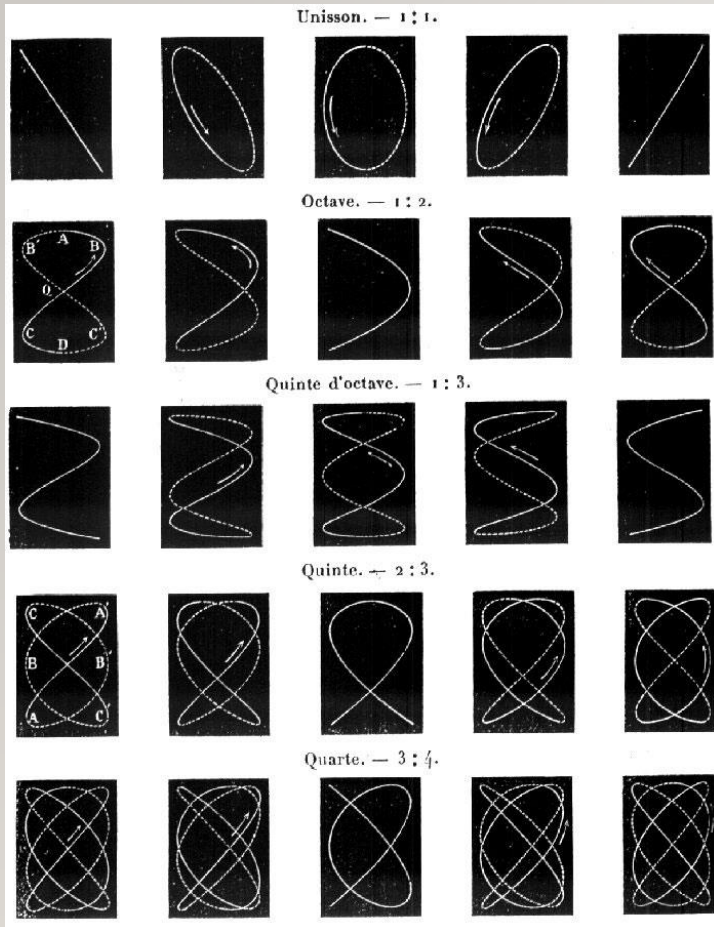

*By this way, it was possible to visualize musical chords!*

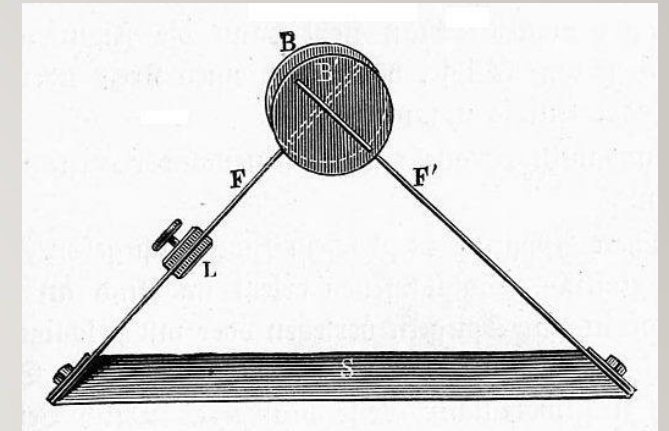
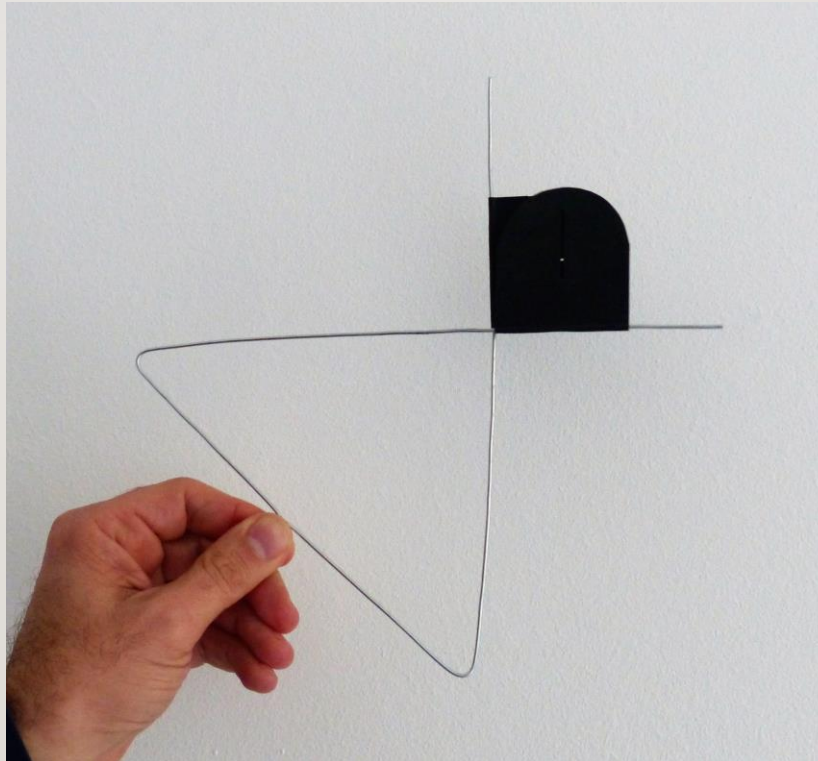

Pfaundler's plate-spring vibrator  
[physik.uibk.ac.at/museum](http://physik.uibk.ac.at/museum)

**Leopold Pfaundler (1839 - 1920)**  
Austrian physicist and chemist.



# APPARATO PER LE FIGURE DI LISSAJOUS

---

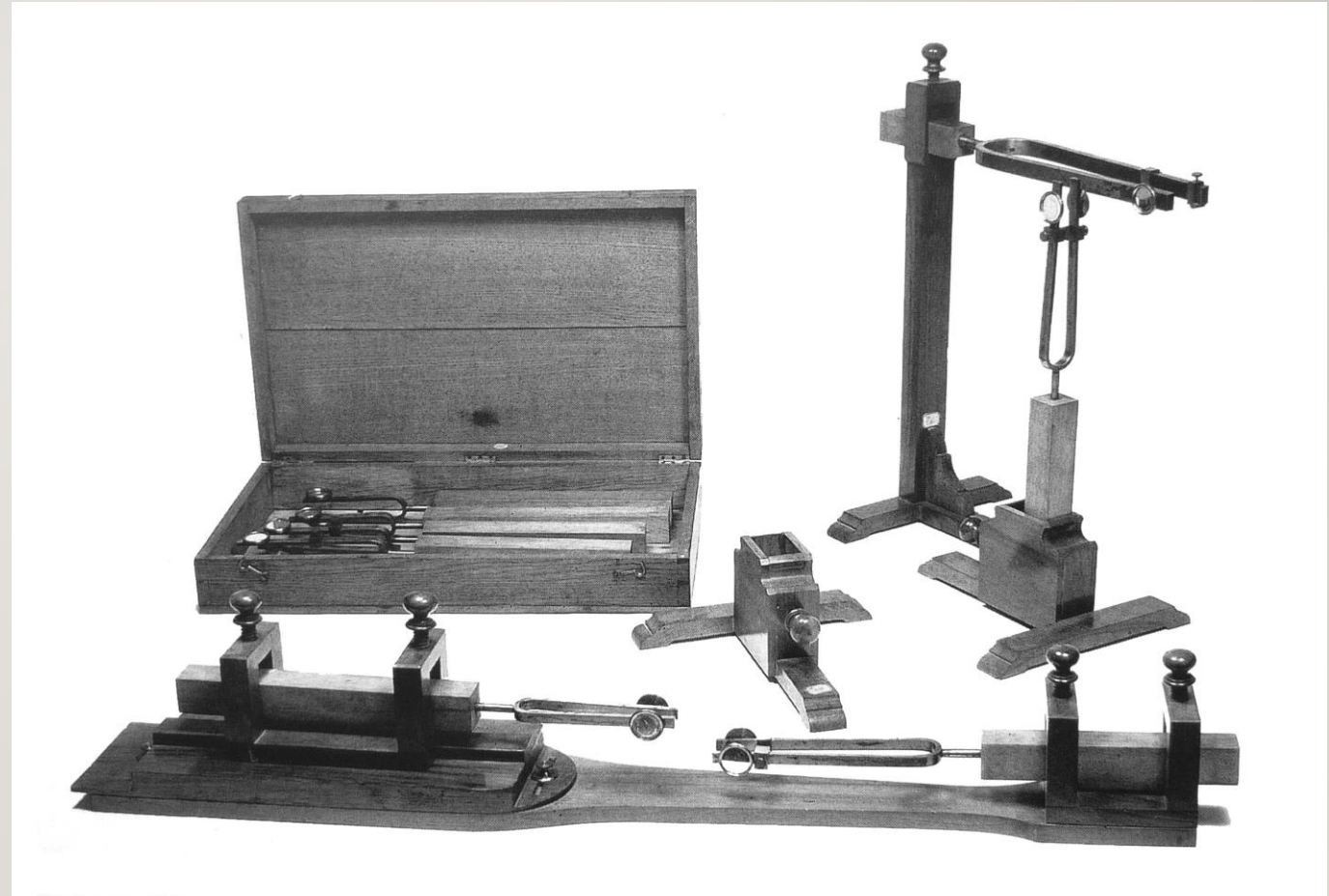

# FIAMME MANOMETRICHE E SPECCHI ROTANTI

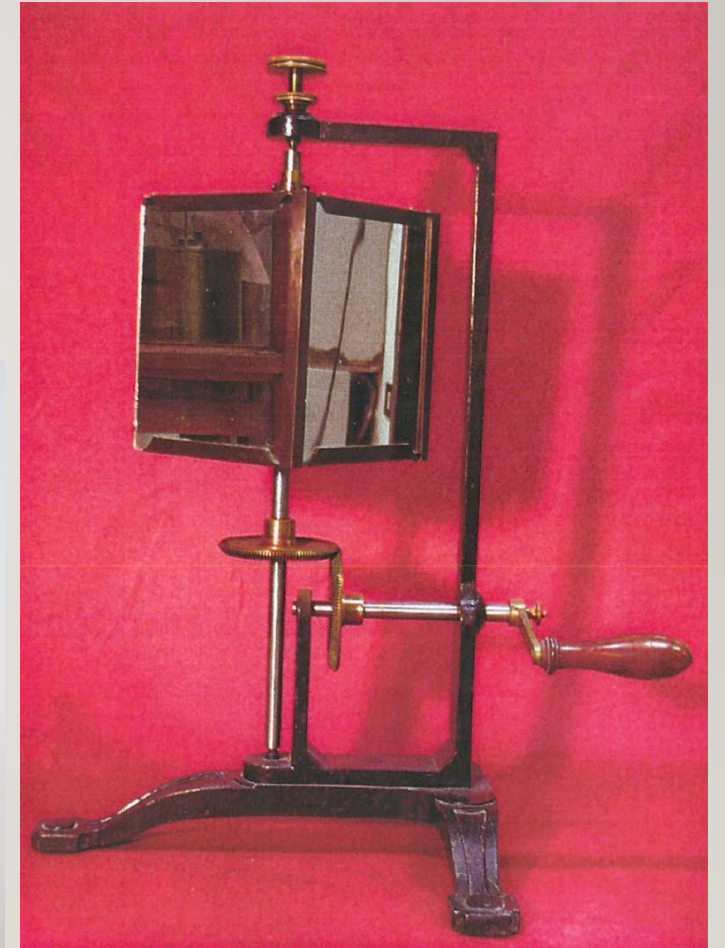
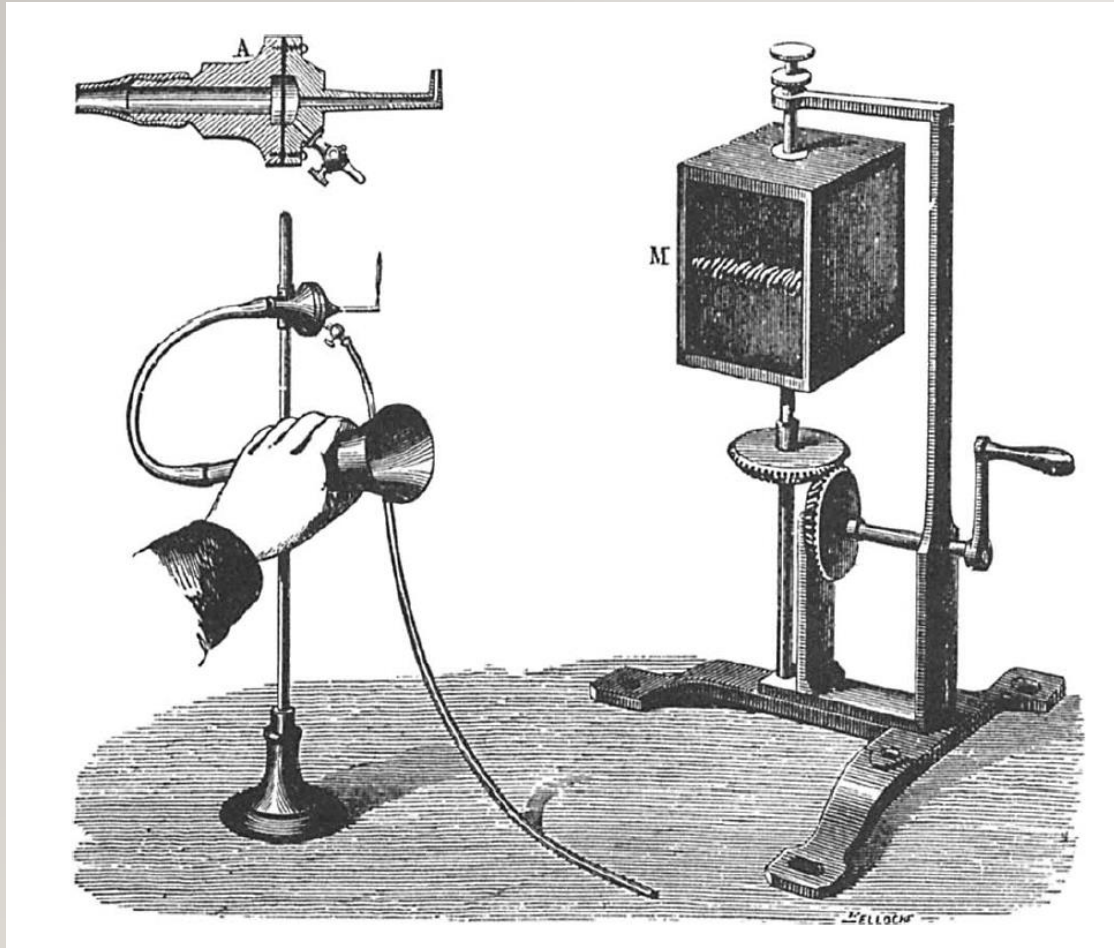

# FIAMME MANOMETRICHE E SPECCHI ROTANTI (2)

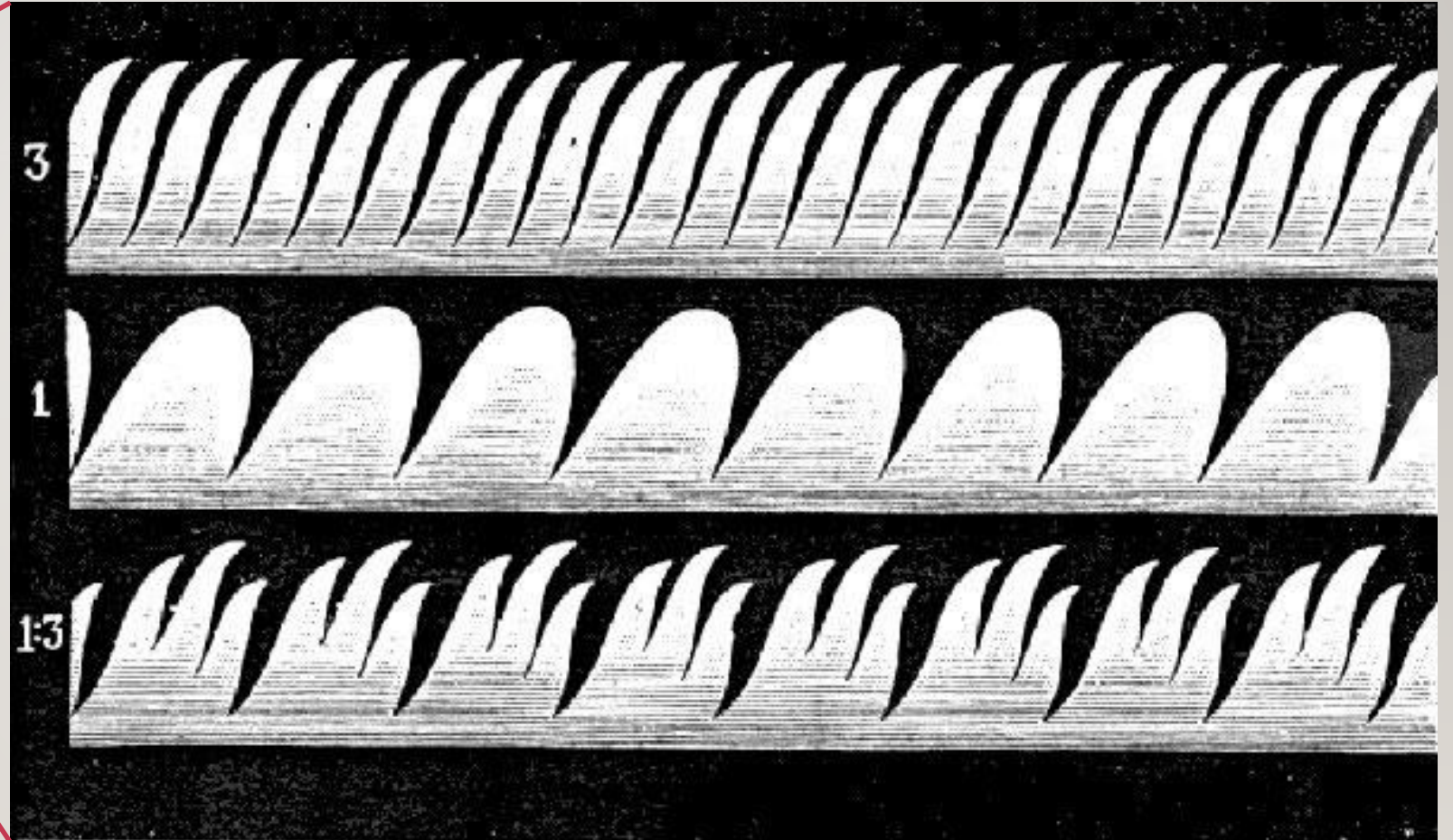
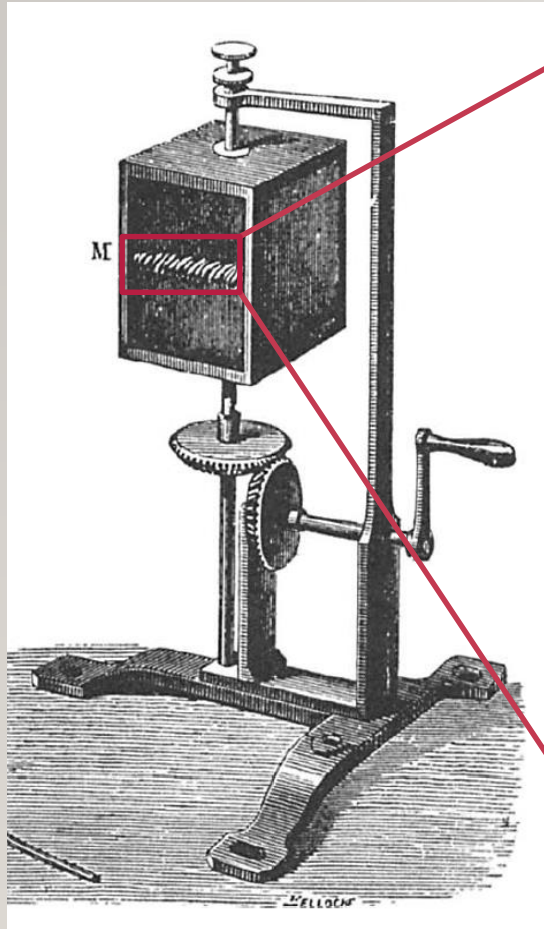

# APPARATO STROBOSCOPICO

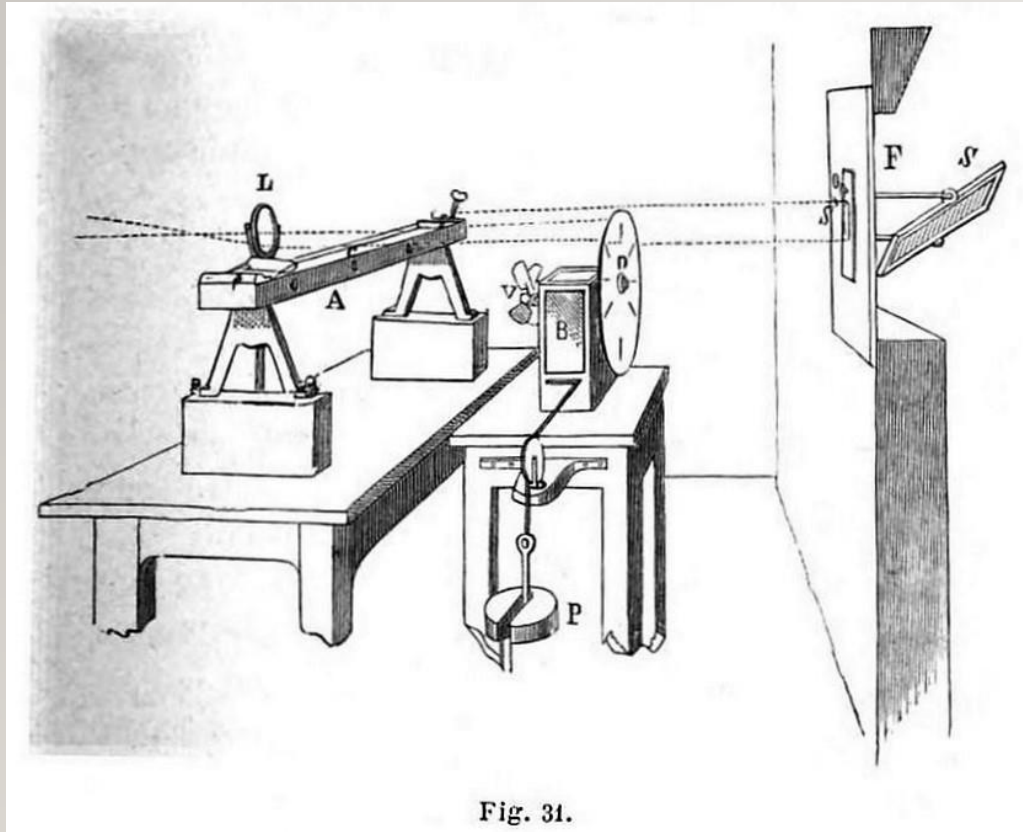

Fig. 31.

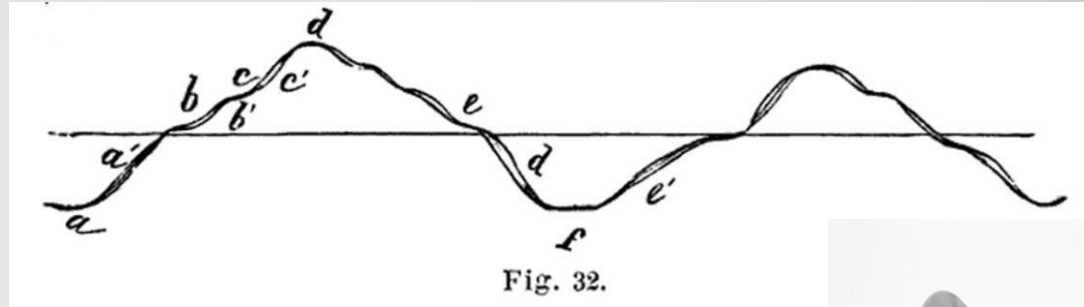
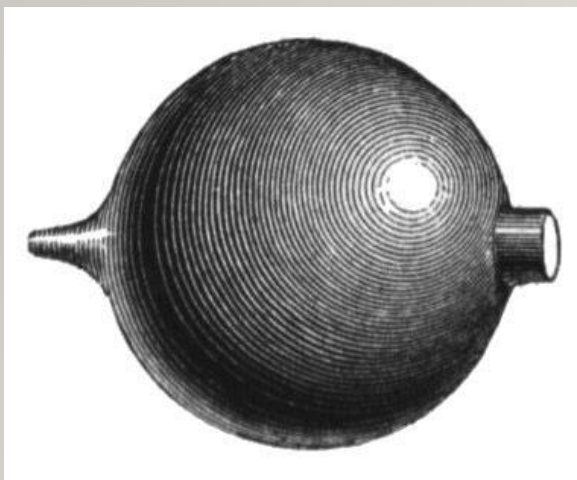

Fig. 32.

Forma osservata quando la corda viene pizzicata a  $1/7$  della sua lunghezza.



# RISUONATORI DI HELMHOLTZ (1821-1894)



Grazie al fenomeno della risonanza, la frequenza propria della cavità viene considerevolmente rinforzata consentendo all'orecchio di percepire distintamente questa frequenza fra le altre eventualmente presenti nel suono.

$$f = \frac{v}{2\pi} \sqrt{\frac{S}{LV}}$$

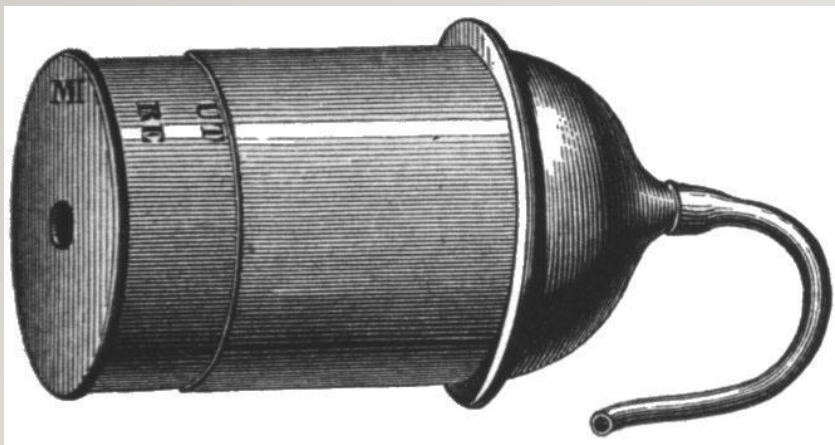

[commons.wikimedia.org](https://commons.wikimedia.org)

# ANALIZZATORE E SINTETIZZATORE DI HELMHOLTZ

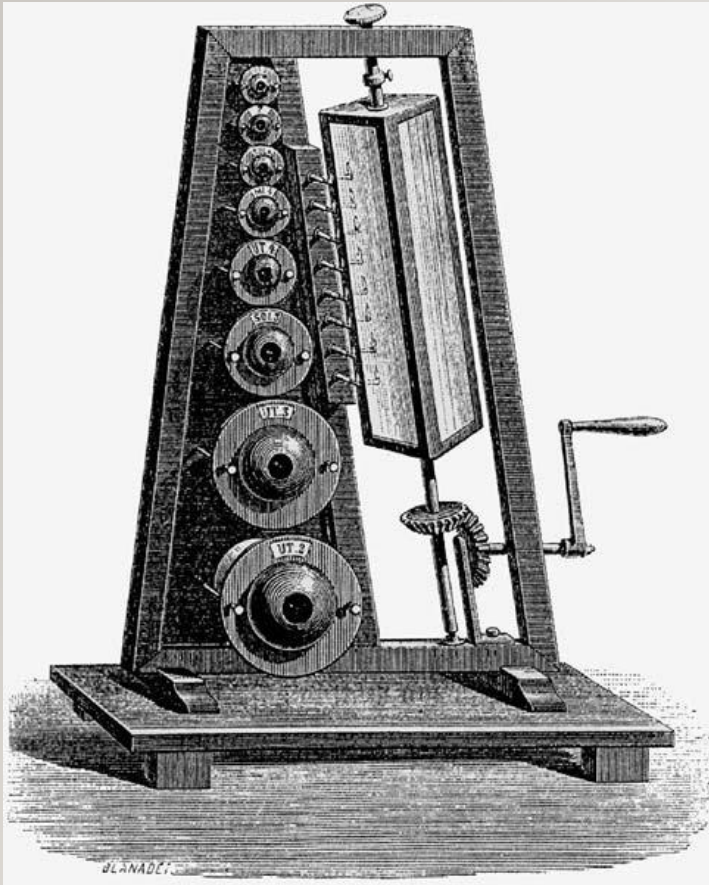

Koenig costruì un analizzatore con 14 risonatori cilindrici telescopici a frequenza variabile (detti risonatori accordabili di Koenig), accordati per le note musicali in modo da coprire l'intervallo di frequenze comprese fra 96 e 1280 Hz.

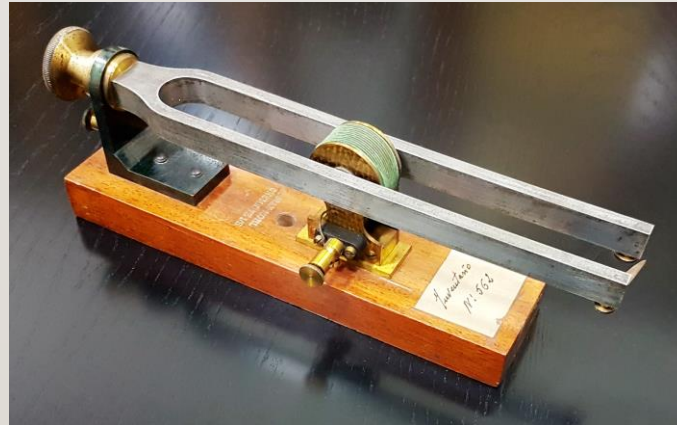

Apparato per l'analisi spettrale dei suoni

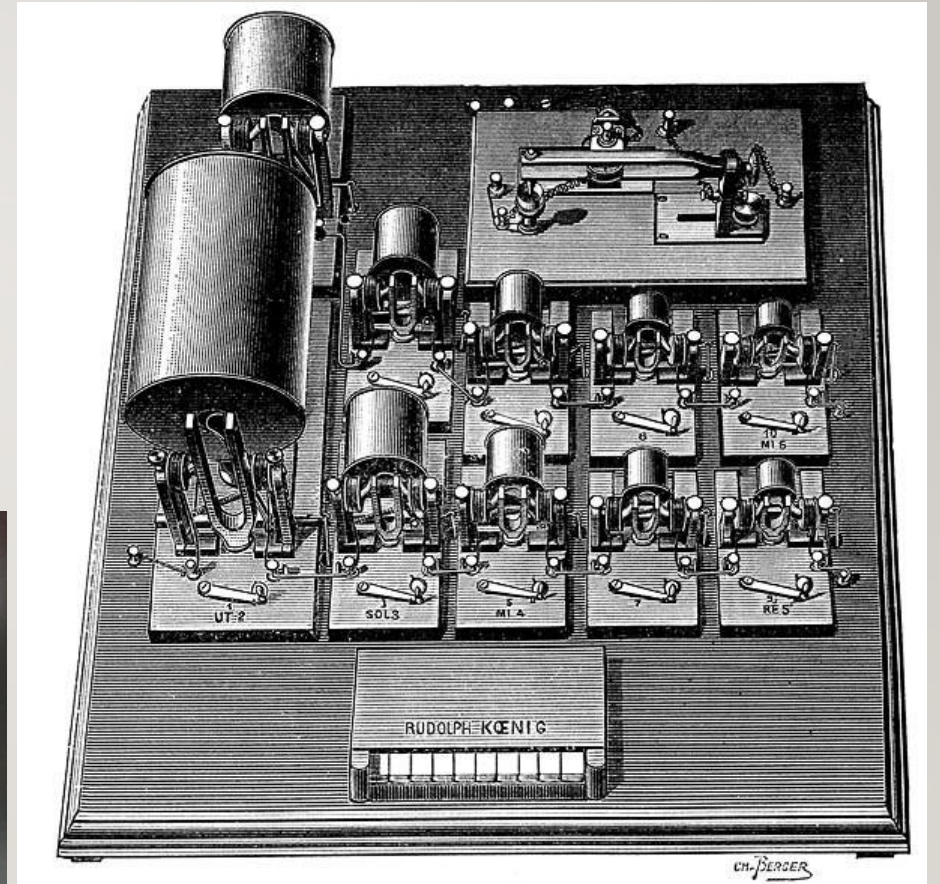

Apparato per la generazione di suoni composti

# ELECTROSTATICS

## Elder marrow electric pendulum

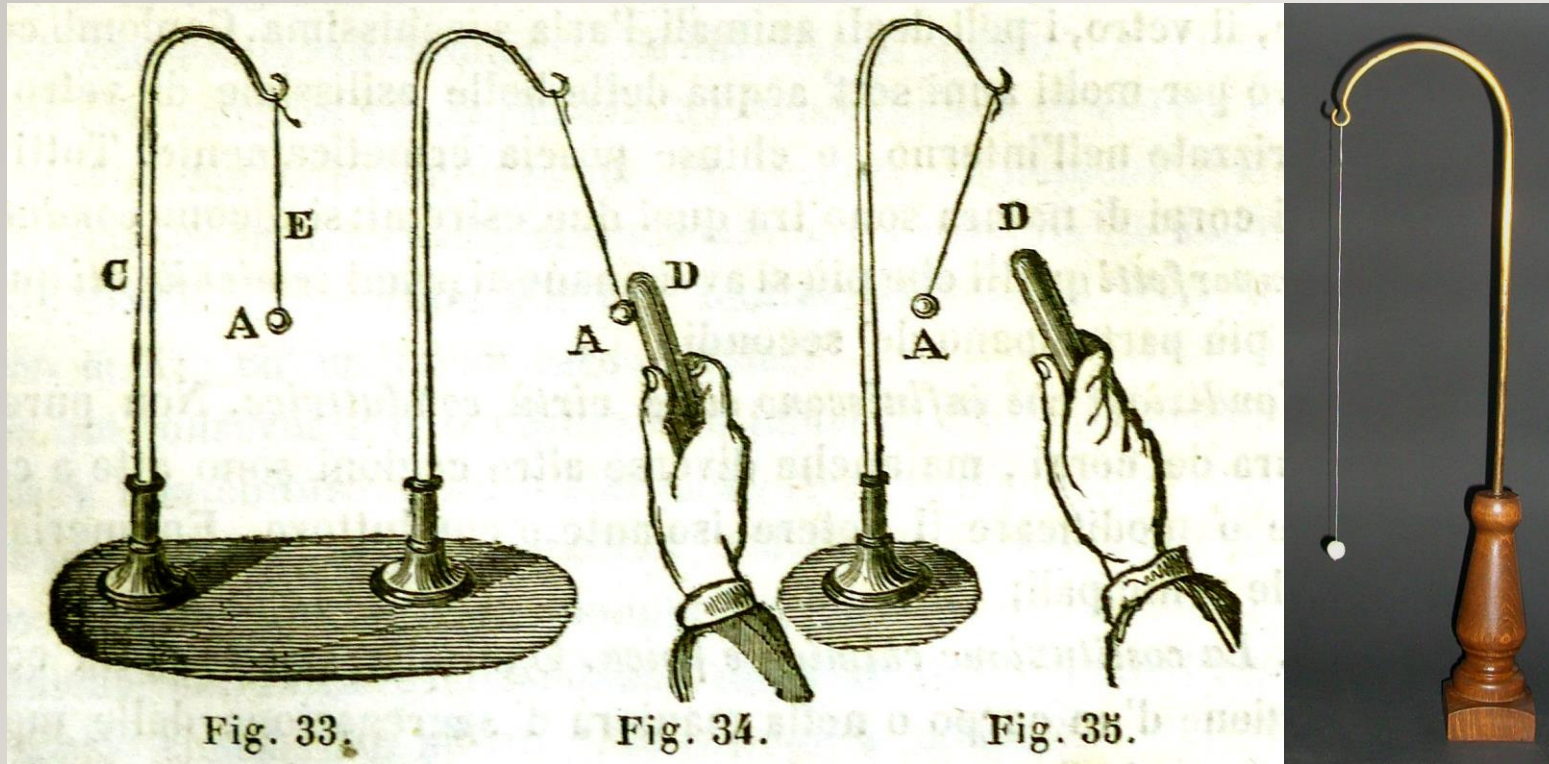

G. Giordano, *Trattato elementare di fisica sperimentale e di fisica terrestre*, 1862

## The Wimshurst machine



# ELECTROMAGNETISM

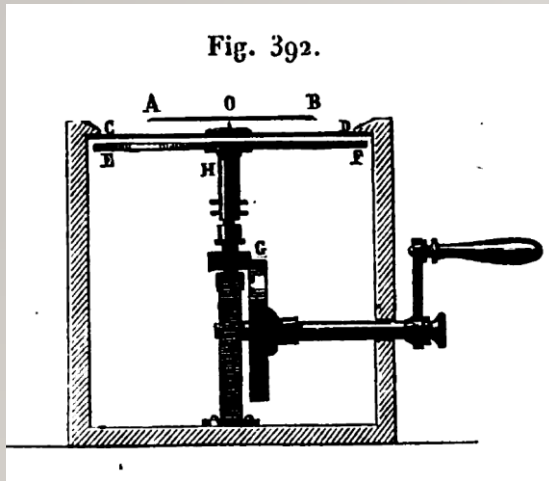

Arago's disk, Ruhmkorff 1868



J. Jamin, *Petit traité de physique*, Gauthier, Paris 1870, pag. 414

## Lenz Law Experiment

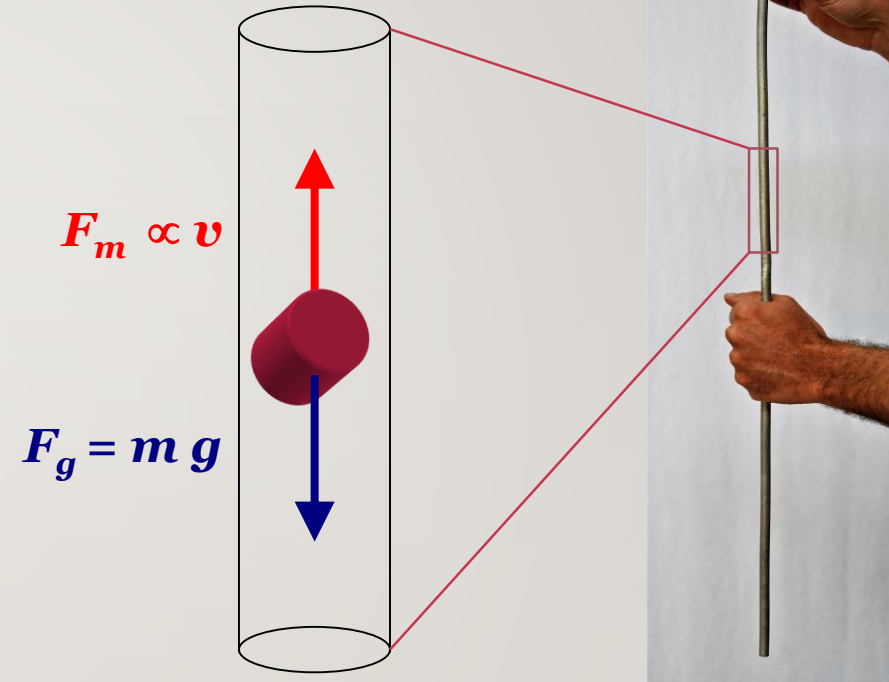

- J. Priest, B. Wade, *A Lenz Law Experiment*, Phys. Teach. 30 (1992) 106
- A. Sconza, G. Torzo, Il freno elettromagnetico: un altro esperimento sulla legge di Lenz, LFnS XXXV (2002) 132



# MODERN PHYSICS: SPECTROSCOPY



Plücker tubes, 1870 ca.

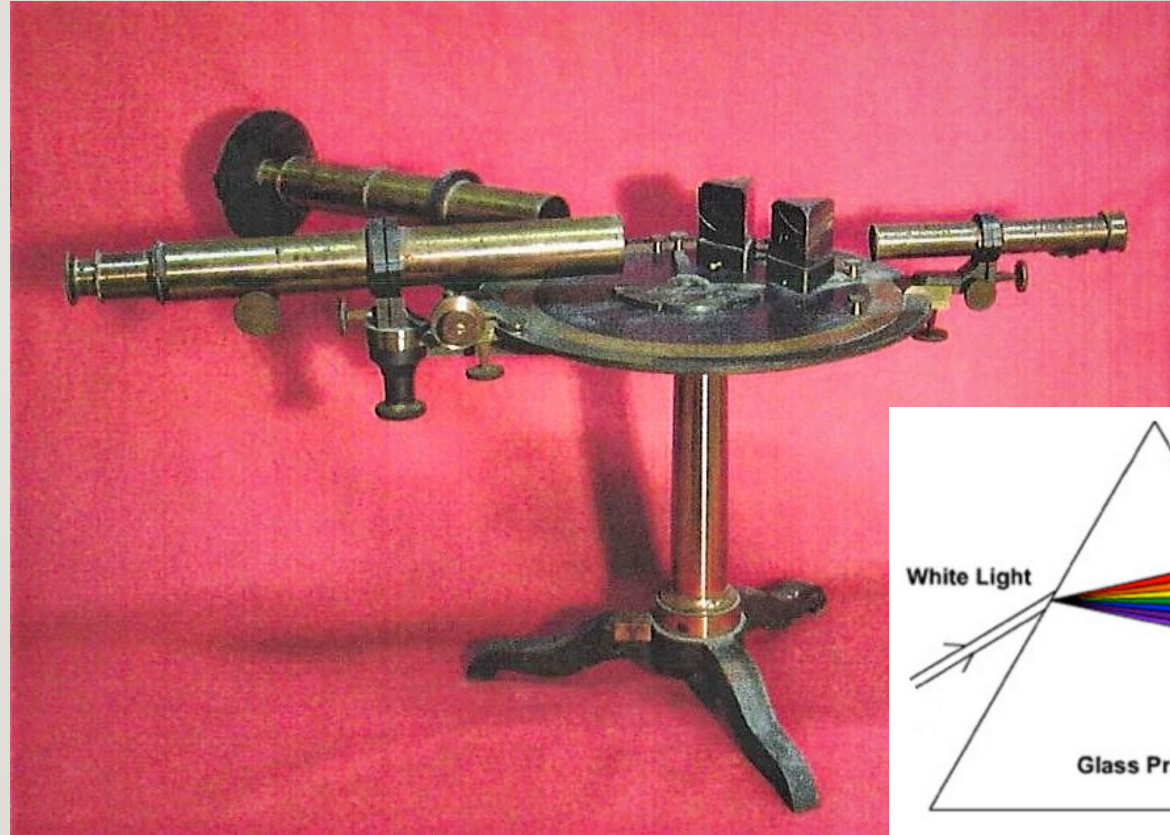

Four-prism spectroscope, by J. Duboscq of Paris, France, bought at Palermo by Pietro Blaserna in 1867.

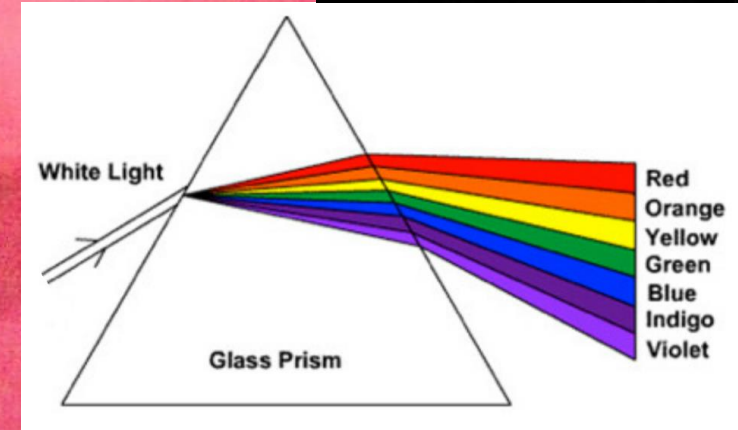
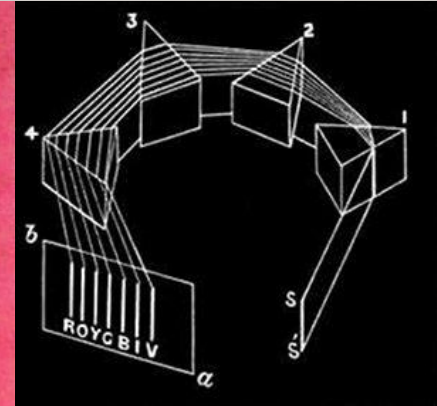

# MODERN PHYSICS: SPECTROSCOPY (2)

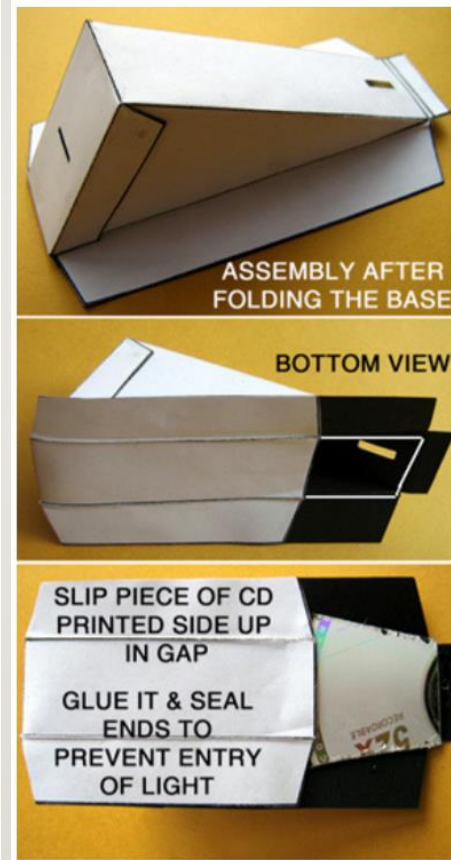
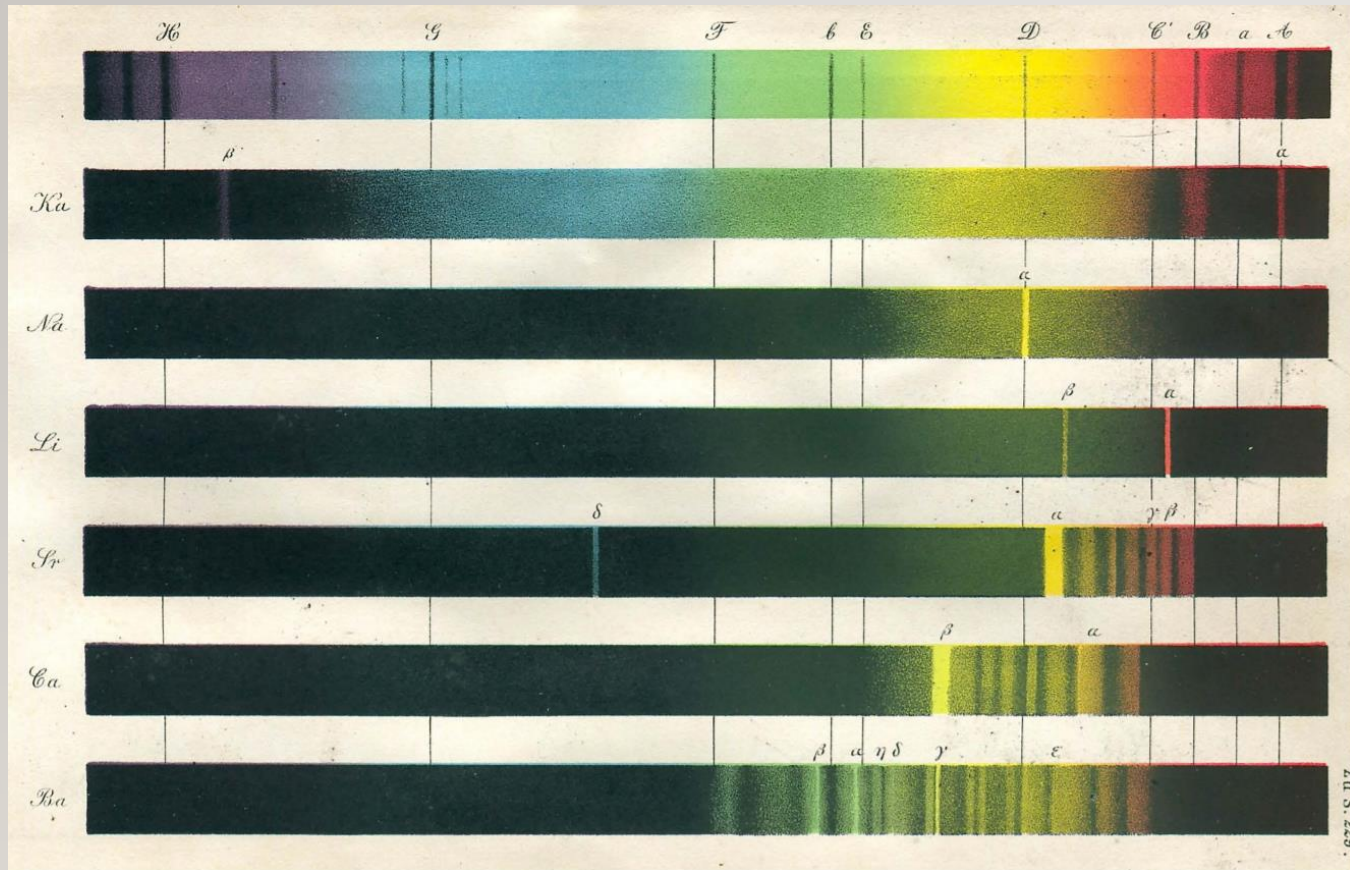

TOYS FROM TRASH

[www.arvindguptatoys.com/  
toys/CDspectroscope0.html](http://www.arvindguptatoys.com/toys/CDspectroscope0.html)

Spectra of elements observed by Bunsen and Kirchhoff.

*Analyse chimique fondée sur les Observations du Spectre*, in Annales de Chimie et de Physique 3rd Series, Volume 52, 1861.

# MODERN PHYSICS: FLUORESCENCE

Uranium glass  
Dubosque, 1871



Figure 5. Blue light emitted by the quinine in commercial tonic water when illuminated with UV light produced by a portable LED torch.

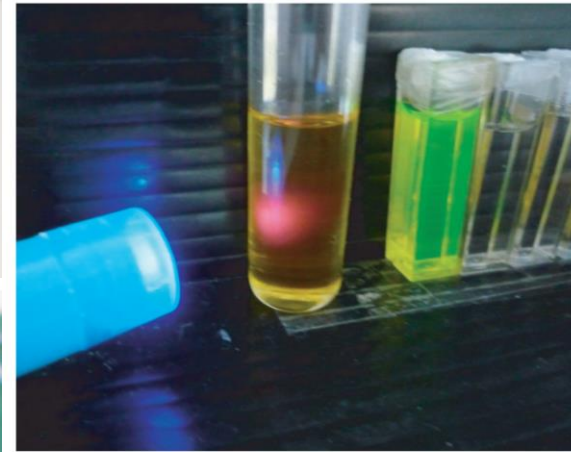
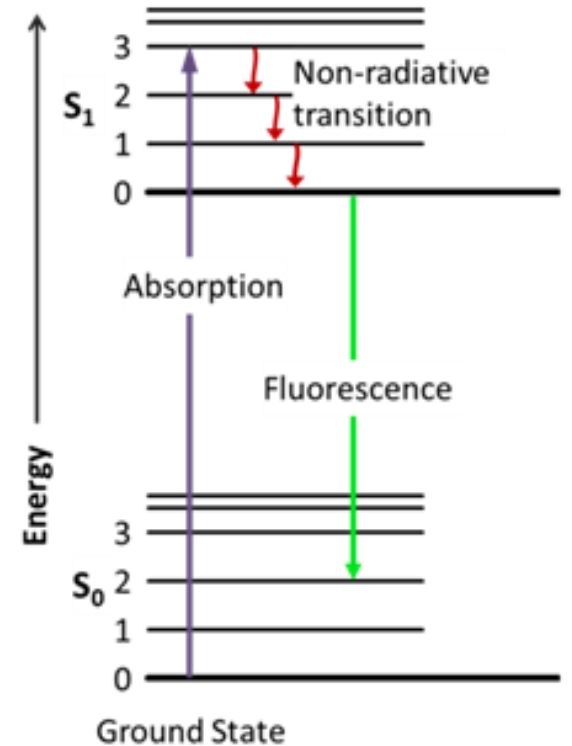

Figure 6. Red light emitted by the extra-virgin olive oil when illuminated with UV light produced by a portable LED torch.



Fluorescent plexiglass

- A. Agliolo Gallitto et al, *Phys. Educ.* **46** (2011) 599
- [www.princetoninstruments.com/applications/fluorescence-phosphorescence-photoluminescence](http://www.princetoninstruments.com/applications/fluorescence-phosphorescence-photoluminescence)

# DUE "CURIOSI" STRUMENTI

The Friction Drum

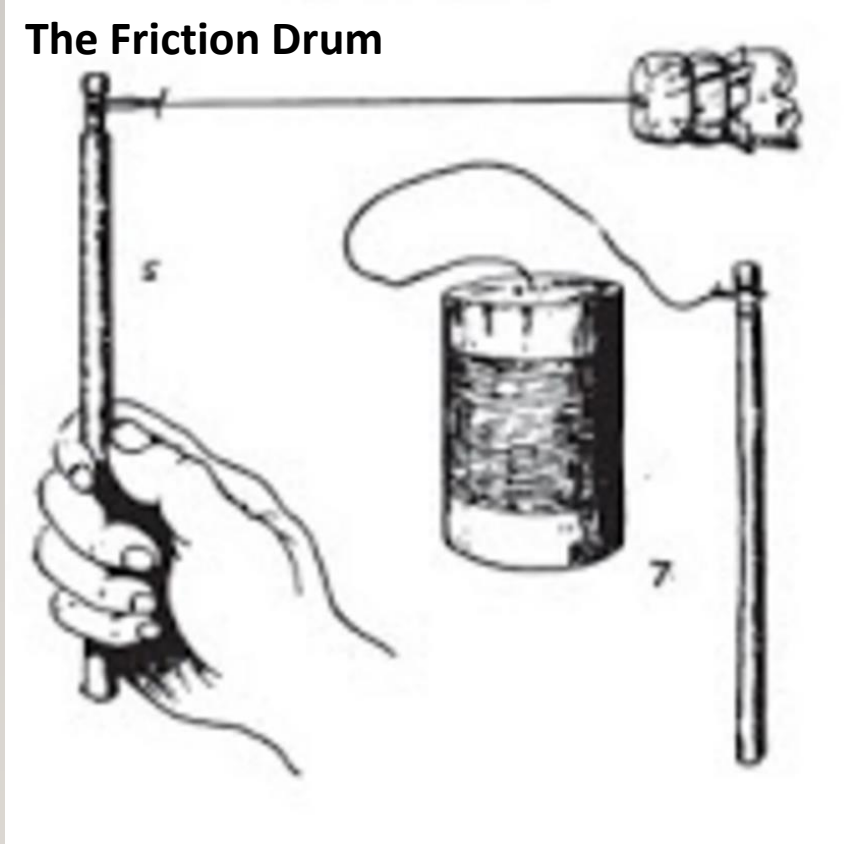

H. Balfour, *The Friction Drum*, J. Anthropological Inst. (1907)

The Notched Stick

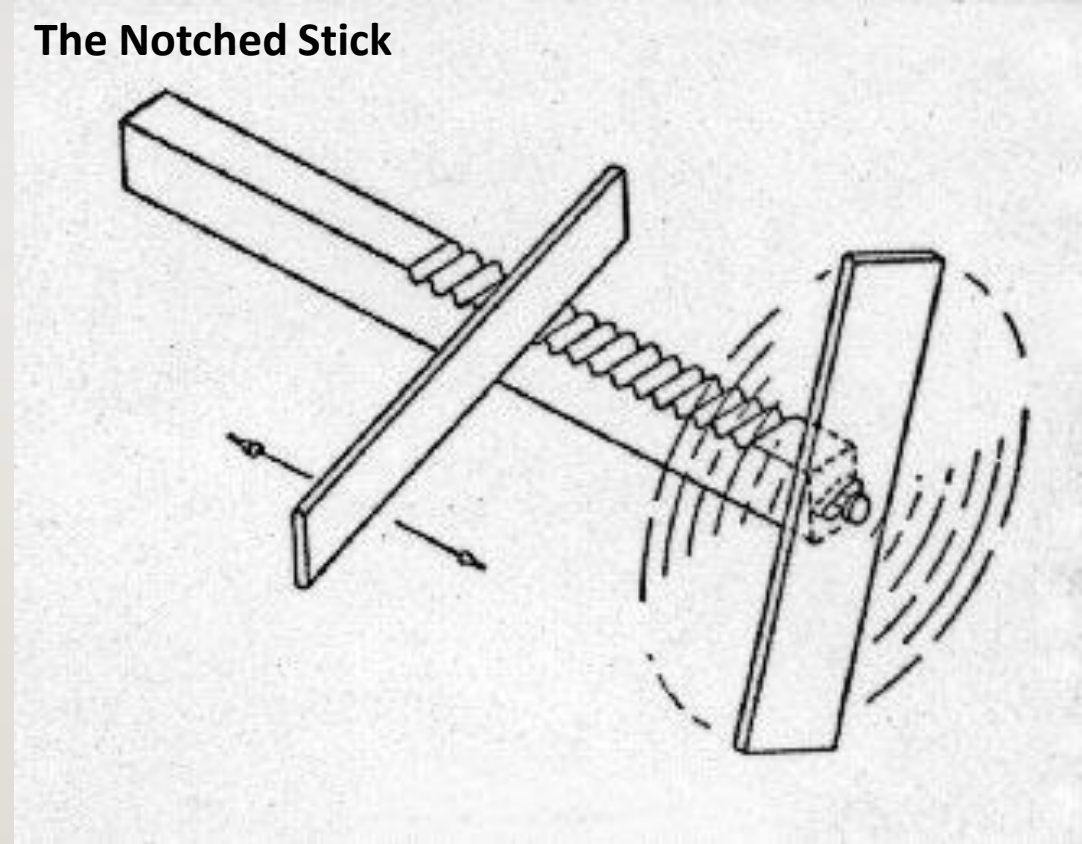

J. Sumner Miller, *The Notched Stick*, American J. Phys. 23 (1955) 176

# THE HISTORICAL COLLECTION ON TV

---







Armillary sphere (ca 1830), attributed to Henry Dreschler, a pupil of the famous Londoner manufacturer Jesse Ramsden (1735 - 1800).

The armillary sphere in the RaiUno movie "Felicia Impastato" directed by Gianfranco Albano in 2016, with Lunetta Savino.



# AGREEMENTS AND PROJECTS

---

## Agreements

-  Liceo Classico “Umberto I” of Palermo, 7.06.2014
-  IIS “Damiani Almeyda – Crispi” of Palermo, 12.01.2015
-  Liceo Musicale “Regina Margherita” of Palermo, 7.10.2016
-  Liceo Scientifico “S. Cannizaro” of Palermo, 7.10.2016

## Projects

-  Bando MIUR DD N. 1524 del 8 luglio 2015 - Titolo 2, “**Musica e Scienza degli Strumenti**”, scuola proponente: Liceo "Regina Margherita" of Palermo
-  (Proposal) PON 2014-2020 “**Didattica museale e laboratoriale: imparo attraverso il conoscere il fare e il condividere per incrementare le competenze di base di scienze integrate**” - Asse I, Azione 10.2.1, proponente school: IIS “Damiani Almeyda - Crispi” of Palermo

# TESTI DI RIFERIMENTO PER GLI STRUMENTI DI ACUSTICA

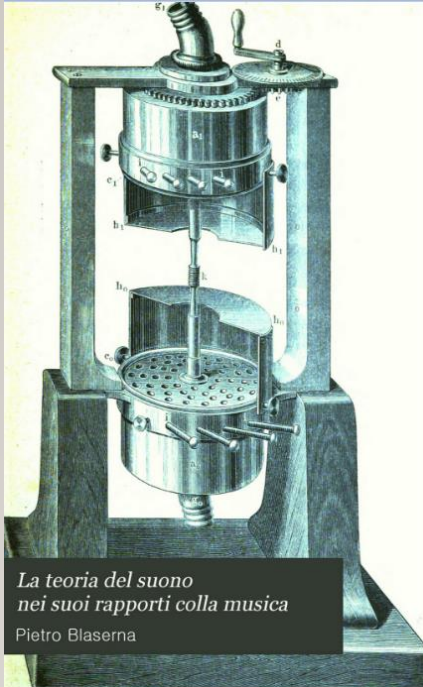

P. Blaserna, *La teoria del suono nei suoi rapporti colla musica*, F.lli Dumolard, Milano 1875

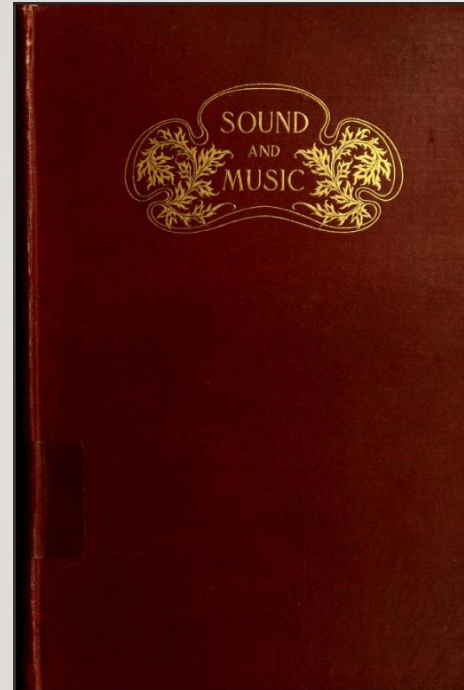

J. A. Zahm, *Sound and music*, A.C. McClurg & Co. Chicago 1900

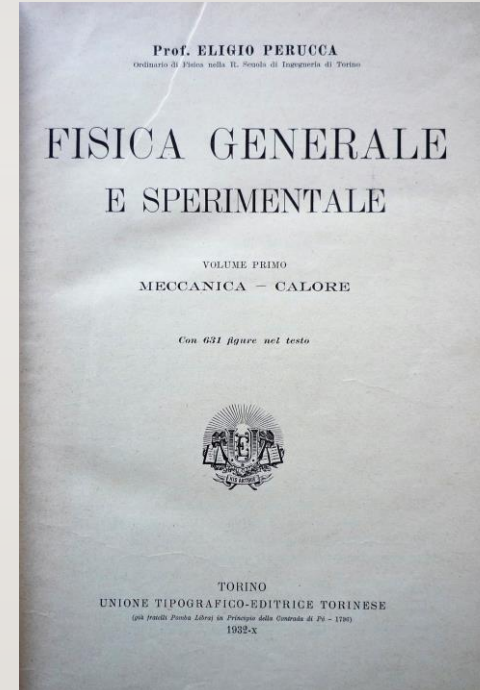



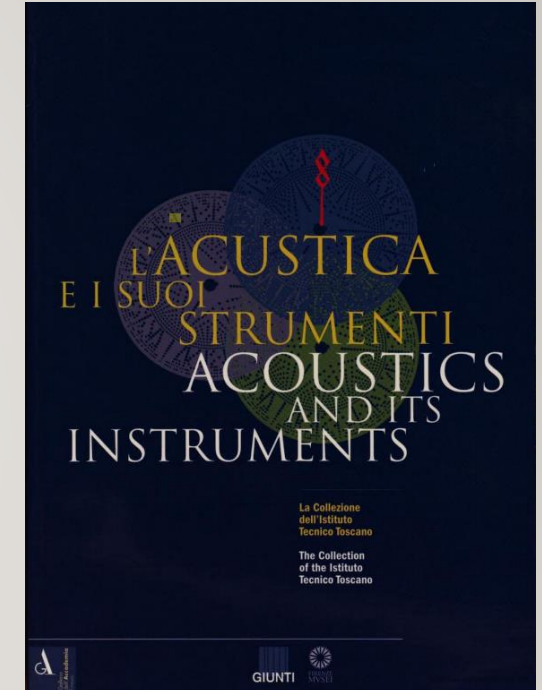









E. Perucca, *Fisica Generale e Sperimentale. Meccanica e calore*, Vol. I, UTET Torino 1932



A. Giatti, M. Miniati, *L'acustica e i suoi strumenti*, Giunti, Firenze 2001

# BIBLIOGRAPHY

---

-  T. Sear, Bulletin of Scientific Instrument Society 132 (2017) 32-33
-  **A. Agliolo Gallitto**, V. Pace, R. Zingales, The silver voltameter: an essential instrument for the definition of the unit of electric current, (2017) submitted
-  **A. Agliolo Gallitto**, V. Pace, R. Zingales, *The Venturi effect and its applications: the hydraulic air pump and the Bunsen burners*, (2017) submitted
-  **A. Agliolo Gallitto**, V. Pace, R. Zingales, *A multidisciplinary learning at the university scientific museums: the Bunsen burners*, (2017) submitted
-  *Atti del Convegno "Gli strumenti scientifici delle collezioni storiche nell'area palermitana"*, Ed. by **A. Agliolo Gallitto**, Quaderni di Ricerca in Didattica (Science), Suppl. n. 7 del 18.02.2015
-  F. Aglione, **A. Agliolo Gallitto** and E. Fiordilino, 'Naughty cylinder' mechanical paradox, Phys. Educ. 48 (2013) 137
-  **A. Agliolo Gallitto** and E. Fiordilino, *The double cone: a mechanical paradox or a geometrical constraint?*, Phys. Educ. 46 (2011) 682
-  **A. Agliolo Gallitto**, S. Agnello, M. Cannas, 'School adopts an experiment': the photoluminescence in extravirgin olive oil and in tonic water, Phys. Educ. 46 (2011) 599
-  [sites.google.com/site/aurelioagliologallitto/collezione-storica/catalogo/acustica](https://sites.google.com/site/aurelioagliologallitto/collezione-storica/catalogo/acustica)
-  [fisicaondemusica.unimore.it](http://fisicaondemusica.unimore.it)
-  Museo di Fisica, Università «La Sapienza» di Roma, [www.phys.uniroma1.it/DipWeb/museo/acustica.htm](http://www.phys.uniroma1.it/DipWeb/museo/acustica.htm)
-  Whipple Museum, University of Cambridge, [www.sites.hps.cam.ac.uk/whipple/explore/acoustics/](http://www.sites.hps.cam.ac.uk/whipple/explore/acoustics/)
-  [www.princetoninstruments.com/applications/fluorescence-phosphorescence-photoluminescence](http://www.princetoninstruments.com/applications/fluorescence-phosphorescence-photoluminescence)





# ACKNOWLEDGEMENTS

## **Collaborators:**

- Ileana Chinnici
- Roberto Zingales

## **Technical support:**

- Filippo Mirabello
  - Vitalba Pace
  - Natale Surano
  - Fulvia Bartolone
- 

**THANKS!**

